

# Evidence of performance

Joint sound reduction of seals

## Test Report

N° 21-002394-PR01

(PB 4-K06-04-en-01)



Client **C.C.E. srl**  
**Costruzioni Chiusure Ermetiche**  
**Via dell'Artigianato 16**  
**35010 Villa del Conte (PD)**  
**Italy**

### Basis

EN ISO 10140-1: 2021  
EN ISO 10140-2: 2021  
EN ISO 717-1: 2020

### Representation

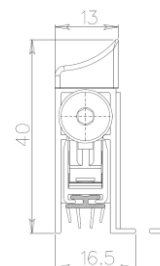

Product	Lowerable floor seal, single-side activation
Designation	Glass
Cross section of sealing groove	Door leaf section without sealing groove
Air gap w	7 mm

### Instructions for use

This procedure is suitable for the comparison of construction products designed for sealing (e.g. gaskets/seals, fillers for joints). The results can be used to evaluate the sound power ratio  $\tau_e$  according to EN ISO 12354-3 Annex B. Using the calculated sound reduction of the joint for the calculation of the overall sound reduction is not a substitute for the sound reduction verification of the overall construction. For Germany the following applies:  
The weighted joint sound reduction index  $R_{s,w}$  can be used for the prognosis of the sound insulation of doors according to DIN 4109-35:2016.

Special features **none**

Weighted sound reduction index of joints  $R_{s,w}$   
Spectrum adaptation terms C and  $C_{tr}$



with air gap  $w = 7$  mm

**$R_{s,w} (C; C_{tr}) = 36 (-1; -1)$  dB**

### Validity

The data and results given relate solely to the tested and described specimen. Testing the sound insulation does not allow any statement to be made on any further characteristics of the present construction regarding performance and quality.

### Notes on publication

The ift Guidance Sheet "Conditions and Guidance for the Use of ift Test Documents" applies.

The cover sheet can be used as abstract.

### Contents

The test report contains a total of 11 pages.

- 1 Object
  - 2 Procedure
  - 3 Detailed results
  - 4 Instructions for use
- Data sheet (1 page)

ift Rosenheim  
15.02.2022

Dr. Joachim Hessinger, Dipl.-Phys.  
Head of Testing Department  
Building Acoustics

Johann Baume, Dipl.-Ing. (FH)  
Operating Testing Officer  
Building Acoustics

Test Report 21-002394-PR01 (PB 4-K06-04-en-01) dated 15.02.2022  
Client C.C.E. srl  
Costruzioni Chiusure Ermetiche, 35010 Villa del Conte (PD) (Italy)



## 1 Object

### 1.1 Description of test specimen

<b>Product</b>	Lowerable floor seal, single-side activation
Product designation	Glass
Dimensions	
Length of joint l	1,000 mm
Depth of joint d	48 mm
Air gap w	7 mm
Joint cover	without cover
Fixing method/fasteners	screw fastened
Cross section of sealing groove	Door leaf section without sealing groove
Material of seal	TPE
Casing	
Material	Aluminium
Cross section	40 mm × 13 mm (outer profile)
Length of seal	976 mm (length of housing) 977 mm (clear width of rebate)
Distance sealing groove – rebate sealing stop	0 mm (screwed on floor seal in rebate seal level)
<b>Special features</b>	none

The description is based on inspection of the test specimen at **ift** Rosenheim. **Item** designations/numbers as well as material specifications were **provided** by **the** client. (Additional data provided by the manufacturer are marked with \*.)

### 1.2 Mounting to test rig

The sound reduction index  $R_s$  of the joint was measured in a mobile joint measuring apparatus as per EN ISO 10140-1:2021, Annex J (see Fig. 1 and 2). This mobile measuring apparatus consists of a high-performance sound insulating element made of metal profiles and Bondal sheet with slide-in cassettes (Fig. 1).

The slide-in cassette consists of a wooden door section reinforced with lead with the groove for the floor seal. This door section is fixed to a receiving device which is adjustable in height. The seal contacts a steel threshold which simulates the floor. This device was manufactured by the ift Rosenheim GmbH in coordination with customer.

The joint geometry of the floor seal in a doorway is simulated in this apparatus. The air gap beneath the door, referred to below as the air gap w, can be varied in the slide-in cassette. (Fig. 2)

Test Report 21-002394-PR01 (PB 4-K06-04-en-01) dated 15.02.2022  
Client C.C.E. srl  
Costruzioni Chiusure Ermetiche, 35010 Villa del Conte (PD) (Italy)

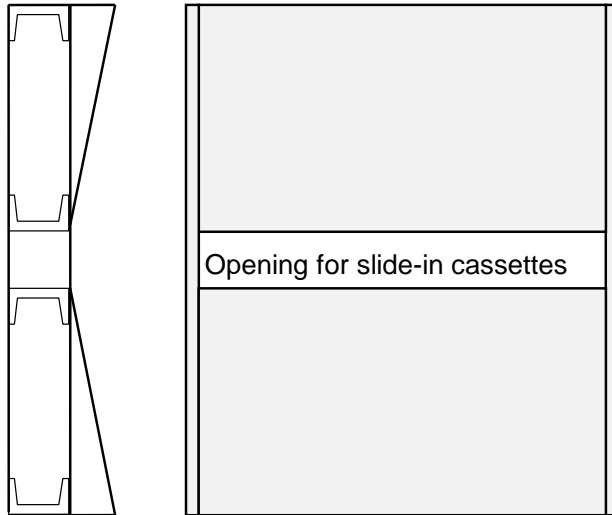

**Fig. 1** Set-up of joint testing apparatus (high performance sound insulating element)

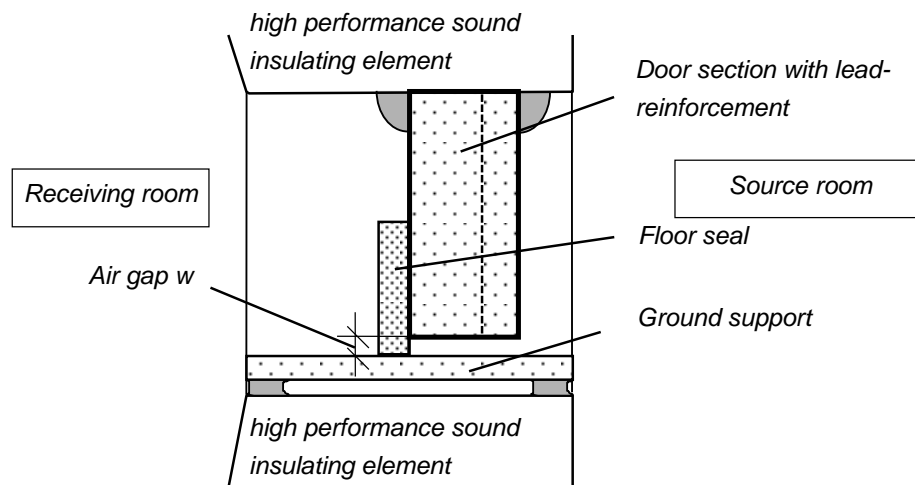

Vertical section

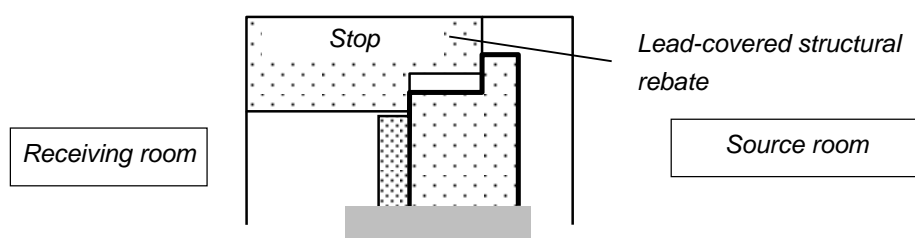

Horizontal section

**Fig. 2** Slide-in cassette (schematic diagram)

Test Report 21-002394-PR01 (PB 4-K06-04-en-01) dated 15.02.2022  
Client C.C.E. srl  
Costruzioni Chiusure Ermetiche, 35010 Villa del Conte (PD) (Italy)

**Geometric data:**

Length of joint:  $l = 1,000 \text{ mm}$

Air gap:  $w = 7 \text{ mm}$

Depth of joint:  $d = 48 \text{ mm}$

The slide-in cassette is mounted to the high-performance sound insulating frame (Fig. 1), which was mounted in the test opening of the window-test rig (ift) according to EN ISO 10140-5. The joints to the test opening were filled with cellular material and sealed with plastic sealant on both sides. The element was mounted to the test rig by **ift** Laboratory for Building Acoustics.

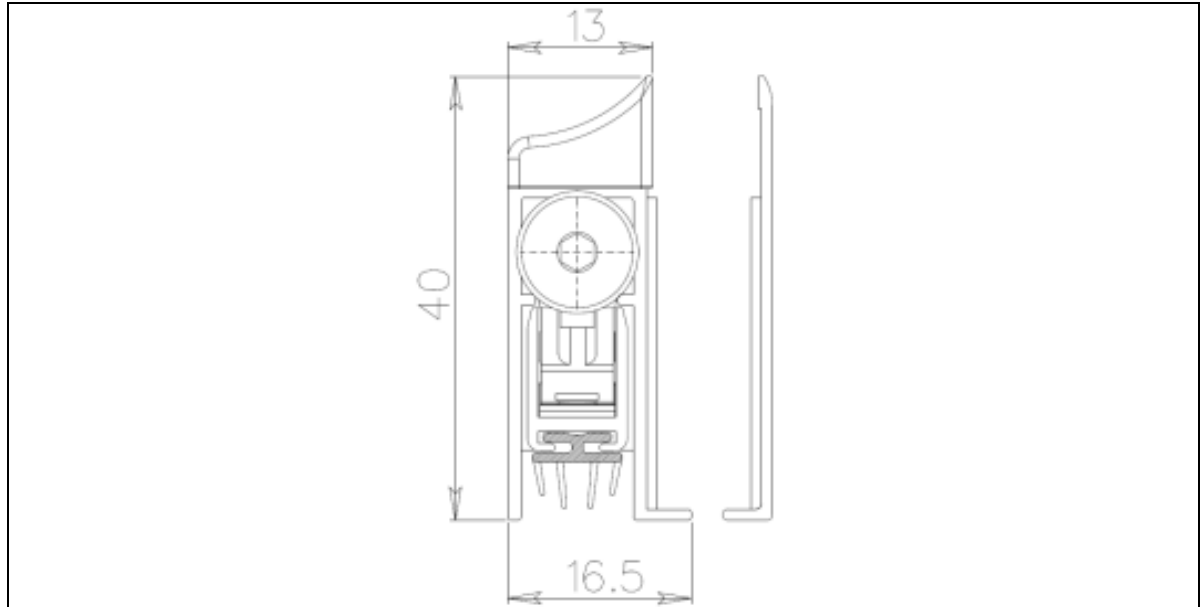

**Fig. 3** Photos of the mounted element (taken by **ift** Laboratory for Building Acoustics)



**Fig. 4** Photo of floor seal in door leaf section

Test Report 21-002394-PR01 (PB 4-K06-04-en-01) dated 15.02.2022  
Client C.C.E. srl  
Costruzioni Chiusure Ermetiche, 35010 Villa del Conte (PD) (Italy)



**Fig. 5** Sectional drawing of floor seal

Test Report 21-002394-PR01 (PB 4-K06-04-en-01) dated 15.02.2022  
Client C.C.E. srl  
Costruzioni Chiusure Ermetiche, 35010 Villa del Conte (PD) (Italy)



## 2 Procedure

### 2.1 Sampling

Selection of Test Specimen	The test specimen were selected by the client.
Number	1
Manufacturer	C.C.E. srl Costruzioni Chiusure Ermetiche
Manufacturing plant	C.C.E. srl Costruzioni Chiusure Ermetiche, Via dell'Artigianato 16, 35010 Villa del Conte (PD) (Italy)
Date of manufacture	July 2021
Responsible for sampling	Mr. Enrico Menegazzo
Delivery at ift	08.09.2021 by the client
ift registration number	54328/04

### 2.2 Methods

#### Basis

EN ISO 10140-1: 2021	Acoustics; Laboratory measurement of sound insulation of building elements - Part 1: Application rules for specific products (ISO 10140-1: 2021)
EN ISO 10140-2: 2021	Acoustics; Laboratory measurement of sound insulation of building elements - Part 2: Measurement of airborne sound insulation (ISO 10140-2: 2021)
EN ISO 717-1: 2020	Acoustics; Rating of sound insulation in buildings and of building elements - Part 1: Airborne sound insulation (ISO 717-1: 2020)

Corresponds to the national German standard/s:

DIN EN ISO 10140-1: 2021-09, DIN EN ISO 10140-2: 2021-09 and  
DIN EN ISO 717-1: 2021-05

Boundary conditions	As specified by the standard
Deviations	There were no deviations to the test method and test conditions, respectively.
Test noise	Pink noise
Measuring filter	One-third-octave band filter
Measurement limits	
Low frequencies	The dimensions of the test room fulfill the dimensions recommended for testing in the frequency range from 50 Hz to 80 Hz as per EN ISO 10140-4:2021 Annex A (informative). A moving loudspeaker was used.
Background noise level	The background noise level in the receiving room was determined during measurement and the receiving room level $L_2$ corrected by calculation as per EN ISO 10140-4:2021 Clause 4.3.

Test Report 21-002394-PR01 (PB 4-K06-04-en-01) dated 15.02.2022  
Client C.C.E. srl  
Costruzioni Chiusure Ermetiche, 35010 Villa del Conte (PD) (Italy)

**Maximum insulation** The maximum insulation of the test rig is partly within the range of the test results. Therefore the tested values are minimum values. A correction by calculation was performed for maximum sound insulation.

**Measurement of reverberation time** Arithmetical mean: two measurements each of 2 loudspeaker and 3 microphone positions (a total of 12 independent measurements).

**Measurement equation A**

$$A = 0,16 \cdot \frac{V}{T} \text{ m}^2$$

**Measurement of sound level difference** Minimum of 2 loudspeaker positions and rotating microphones

**Measurement equation**

$$R_s = L_1 - L_2 + 10 \log \frac{S_N \cdot l}{A \cdot l_N} \text{ dB}$$

**KEY**

- R<sub>S</sub> Joint sound reduction index in dB
- L<sub>1</sub> Sound pressure level source room in dB
- L<sub>2</sub> Sound pressure level receiving room in dB
- l Length of joint in m
- S<sub>N</sub> Reference area (1 m<sup>2</sup>)
- l<sub>N</sub> Reference length (1 m)
- A Equivalent absorption area in m<sup>2</sup>
- V Volume of receiving room in m<sup>3</sup>
- T Reverberation time in s

This sound reduction index of joints is comparable to the linear sound reduction index of a building component with 1 m joint length for each m<sup>2</sup> area and where the sound is transmitted only through the joint.

If the joint is combined with a building component (e.g. door with area S and sound reduction index R) and assuming the building component's area S<sub>1</sub> >> than the opening area of the joint (w · l, w = joint width), for the associated joint length l<sub>0</sub> = 1 m the resulting sound reduction index R<sub>i,w</sub> is calculated as follows:

$$R_{i,w} = -10 \cdot \log \left( 10^{\frac{R_w}{10}} + \frac{l \cdot l_0}{S} \cdot 10^{\frac{R_{s,w}}{10}} \right) \text{ dB}$$

**2.3 Test equipment**

Device	Type	Manufacturer
Integrating sound meter	Type Nortronic 140	Norsonic-Tippkemper
Microphone preamplifiers	Type 1201	Norsonic-Tippkemper
Microphone unit	Type 1220	Norsonic-Tippkemper
Calibrator	Type 1251	Norsonic-Tippkemper
Dodecahedron loudspeakers	Type 229	Norsonic-Tippkemper
Amplifier	Type 335	Norsonic-Tippkemper
Rotating microphone boom	Type Nor 265	Norsonic-Tippkemper

Test Report 21-002394-PR01 (PB 4-K06-04-en-01) dated 15.02.2022  
Client C.C.E. srl  
Costruzioni Chiusure Ermetiche, 35010 Villa del Conte (PD) (Italy)

The ift Laboratory for Building Acoustics participates in comparative measurements at the Physikalisch-Technische Bundesanstalt (PTB) in Braunschweig every three years, the last one was in April 2019. The sound level meter used, Series No. 1406469 and 1406470, was calibrated by the Eichamt Dortmund (calibration agency) on 17.03.2020. The calibration is valid until 31.12.2022. LBME NRW (Eichamt Dortmund) meets the requirements for measurement traceability in connection with DIN EN ISO/IEC 17025. The sound level meter used, Serial no. 1406469/1406470, were DKD calibrated by the company Norsonic Tippkemper (DKD - Deutscher Kalibrierdienst "German Calibration Service") on 16.03.2020.

## 2.4 Procedure

Date 08.09.2021  
Operating testing officer Florian Dangl

## 3 Detailed results

The values of the measured sound reduction index  $R_S$  of the joint for the tested seal are plotted against frequency in the data sheets (Annex). Based on EN ISO 717-1, this is used to calculate the weighted sound reduction index  $R_{S,w}$  of the joint and the spectrum adaptation terms  $C$  and  $C_{tr}$ , related to joint length  $l = 1,000$  mm, for the frequency range 100 Hz to 3,150 Hz.

The diagram includes the maximum sound insulation of the test set-up (related to  $l = 1,000$  mm), with a maximum weighted sound reduction index of joints  $R_{S,w \max}(C; C_{tr}) = 58$  (-1; -3) dB.

The resulting sound reduction indices for joints are partly in the range for maximum sound insulation; in these cases the values obtained are minimum values. For maximum insulation, it has been corrected by calculation as per EN ISO 10140-1:2021, Annex J.

Table 1 and diagram 1 lists the weighted sound reduction index of joints as a function of air gap  $w$ .

**Table 1** Test results for floor seal Glass

Seal type Glass	Measures taken, comments
$R_{S,w}(C;C_{tr})$ in dB	
36 (-1; -1)	Air gap 7 mm
58 (-1; -3)	Maximum sound insulation

The measurement was made for nominal size  $w_0 = 7$  mm for air gap at floor level according to DIN 18101 (2014-08).



## 4 Instructions for use

### 4.1 Application for DIN 4109: 2016 or 2018

#### Basis

DIN 4109-1: 2018-01	Sound insulation in buildings - Part 1: Minimum requirements
DIN 4109-2: 2018-01	Sound insulation in buildings - Part 2: Verification of compliance with the requirements by calculation
DIN 4109-35: 2016-07	Sound insulation in buildings - Part 35: Data for verification of sound insulation (component catalogue) – Elements, windows, doors, curtain walling

The weighted joint sound reduction index  $R_{s,w}$  determined in accordance with Section 3 can be used to determine the sound insulation of doors in accordance with the tabulation method from DIN 4109-35.  $R_{s,w}$  corresponds directly to  $R_{s,w}$  for floor seals from Table 4 in this standard.

### 4.2 Uncertainty of measurement, single number ratings in $1/10$ dB

#### Basis

EN ISO 12999-1: 2020	Acoustics; Determination and application of measurement uncertainties in building acoustics, Part 1: Sound insulation (ISO 12999-1: 2020)
----------------------	---

The resulting weighted joint sound reduction index (in  $1/10$  dB with measurement uncertainty), determined on the basis of EN ISO 717-1:2020 is:

$$R_{s,w} = 36.4 \text{ dB} \pm 1.2 \text{ dB (air gap } w = 7 \text{ mm)}$$

The specified measurement uncertainty is the average standard deviation of laboratory measurements (standard measurement uncertainty  $\sigma_R$  for measurement situation A: Characterization of a building component by laboratory measurements as per EN ISO 12999-1:2020, Table 3  $\sigma_R = 1.2$  dB).

### 4.3 General Information

This procedure is suitable for the comparison of construction products designed for sealing (e.g. gaskets/seals, fillers for joints). The results can be used to evaluate the sound power ratio  $\tau_e$  as per DIN EN ISO 12354-3 Annex B. Using the calculated sound reduction of the joint for the calculation of the overall sound reduction is not a substitute for the sound reduction verification of the overall construction.

Test Report 21-002394-PR01 (PB 4-K06-04-en-01) dated 15.02.2022  
Client C.C.E. srl  
Costruzioni Chiusure Ermetiche, 35010 Villa del Conte (PD) (Italy)



### **Remark on transfer of the test results**

For practical application of the seal in a door, refer to the enclosed guidance sheet „Bestimmung der Schalldämmung einer Tür mit Bodendichtung“ (Determination of sound insulation of a door with floor seal). The sound reduction indices measured for the seals refer to solid and flat floor surfaces. They shall not be applied to uneven surfaces or carpets.

**ift** Rosenheim  
Laboratory for Building Acoustics  
15.02.2022

# Joint sound reduction index according to ISO 10140-1

Determination of sound reduction index of joints



Client: C.C.E. srl

Costruzioni Chiusure Ermetiche, 35010 Villa del Conte (PD), Italy

Product designation Glass

## Design of test specimen

Lowerable floor seal, single-side activation

Joint size

Length l 1,000 mm

Depth d 48 mm

Air gap w 7 mm

Seal cross section 40 mm x 13 mm (outer profile)

Drawing of measuring arrangement (not scaled)

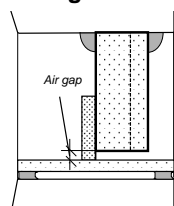

Test date 08.09.2021

Length of joint l 1.0 m

Test rig as per EN ISO 10140-5

Partition wall Double-leaf concrete wall

Test noise Pink noise

Volumes of test rooms  $V_S = 109.9 \text{ m}^3$

$V_R = 101.3 \text{ m}^3$

Maximum joint sound reduction index

$R_{S,w,max} = 58 \text{ dB}$  (related to test length)

Mounting conditions

Mounting of the cassette in high performance sound insulating element.

Climate of test rooms 22°C / 48 % RH

Static air pressure 966 hPa

f in Hz	$R_s$ in dB
50	$\geq 36.8^*$
63	$\geq 46.3^*$
80	$\geq 45.4^*$
100	$\geq 46.6^*$
125	$\geq 46.6^*$
160	$\geq 46.4^*$
200	$\geq 50.3^*$
250	$\geq 49.1^*$
315	$\geq 47.7^*$
400	$\geq 50.5^*$
500	48.2
630	44.9
800	40.1
1,000	33.2
1,250	31.2
1,600	32.3
2,000	35.0
2,500	37.4
3,150	41.6
4,000	48.0
5,000	48.7

\* minimum value

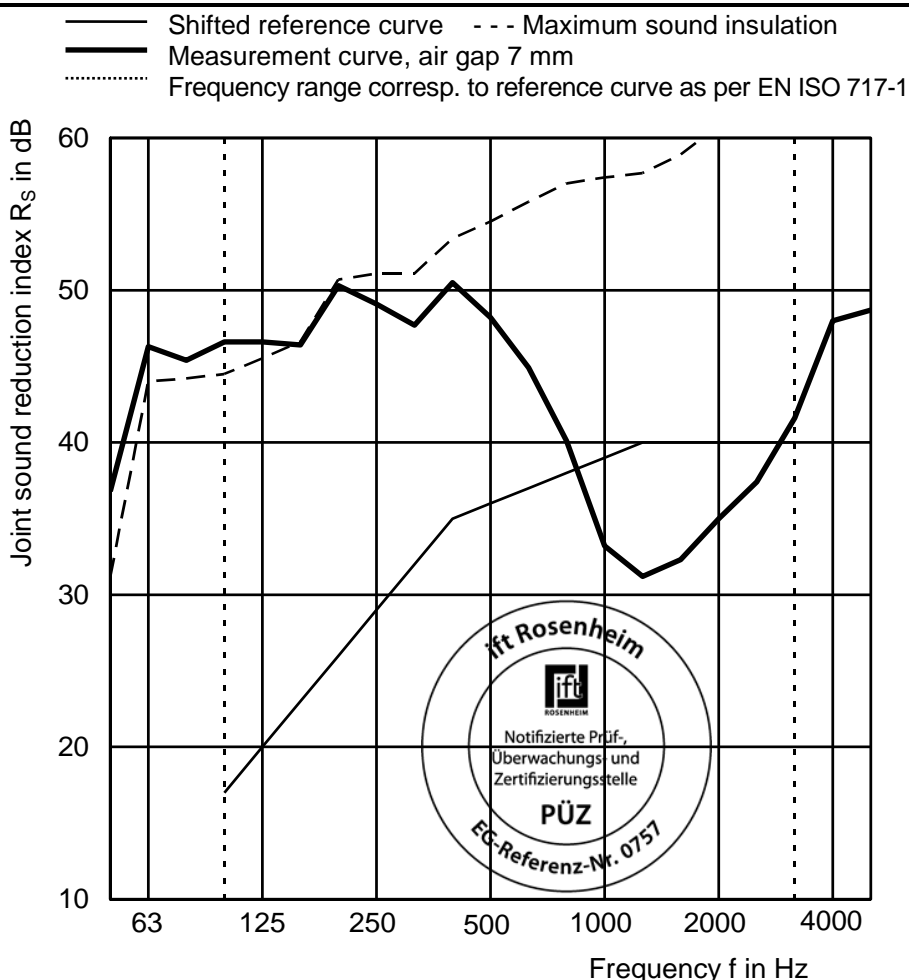

Rating according to EN ISO 717-1 (in third octave bands)

$R_{S,w,0} (C; C_{tr}) = 36 (-1; -1) \text{ dB}$

$C_{50-3150} = -1 \text{ dB}; C_{100-5000} = 0 \text{ dB}; C_{50-5000} = 0 \text{ dB}$

$C_{tr,50-3150} = -1 \text{ dB}; C_{tr,100-5000} = -1 \text{ dB}; C_{tr,50-5000} = -1 \text{ dB}$

Test report n° 21-002394-PR01 (PB 4-K06-04-en-01)

Page 11 of 11, data sheet n° T07

ift Rosenheim

Laboratory for Building Acoustics

*J. Baume*  
Dipl. Ing. (FH) Johann Baume  
Operating Testing Officer