

We Care about the environment. This sheet is print with 100% recyclable paper

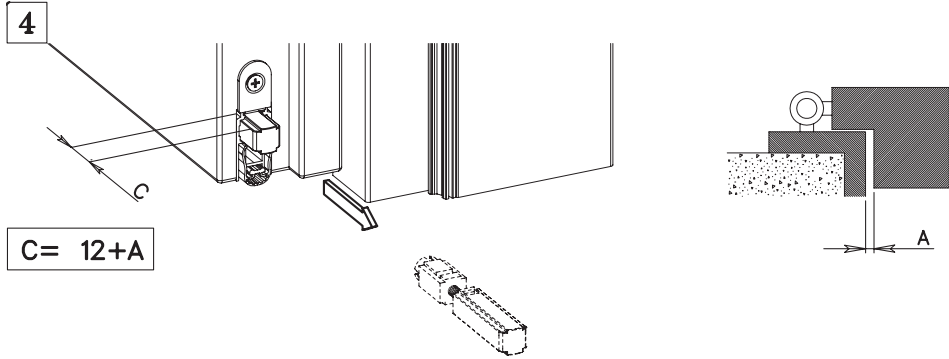

$C = 12 + A$

Macroregolazione

Approssimazione alla quota "C" con step di 7 mm
Approximate C quota by steps of 7mm

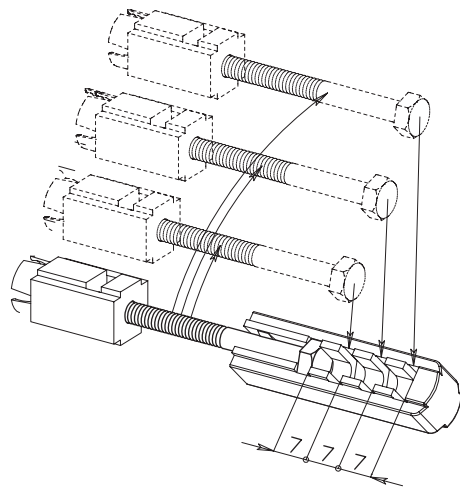

Microregolazione

Avvitare/svitare per ottenere quota "C" e variare pressione alla guarnizione
Screw/Unscrew to obtain "C" quota and modify seal pressure

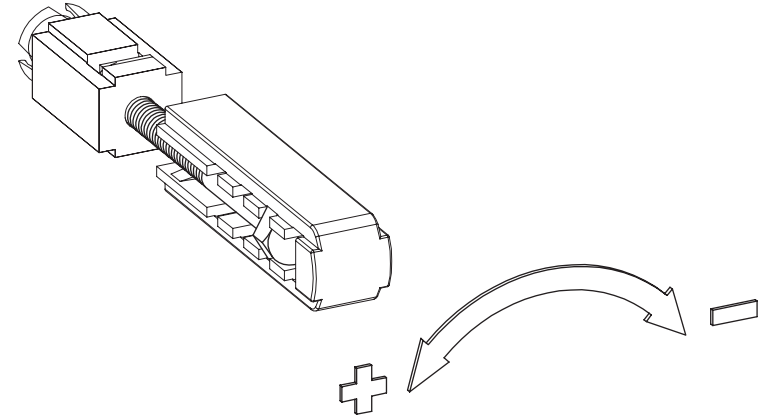

5

