

1 MONTAGGIO SU PORTE A BATTENTE CON TELAIO METALLICO
FITTING ON METAL FRAMED LEAF DOORS

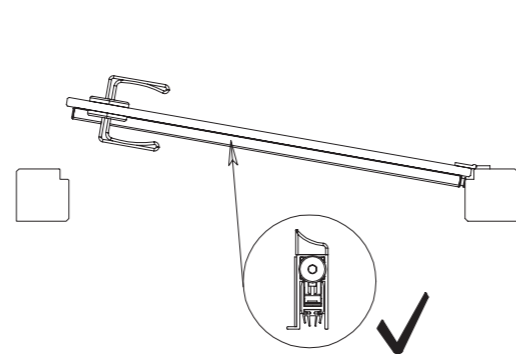

Montaggio corretto
Correct Fitting

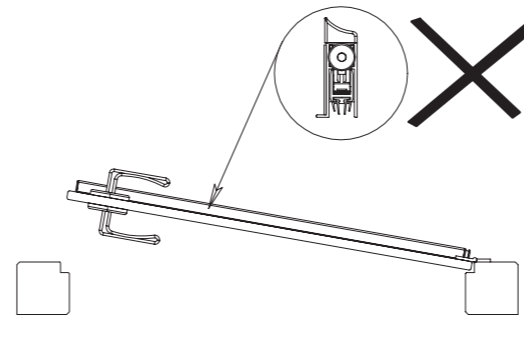

Montaggio errato
Wrong Fitting

2 MONTAGGIO SU PORTE A BATTENTE SENZA TELAIO
FITTING ON LEAF DOORS WITHOUT FRAME

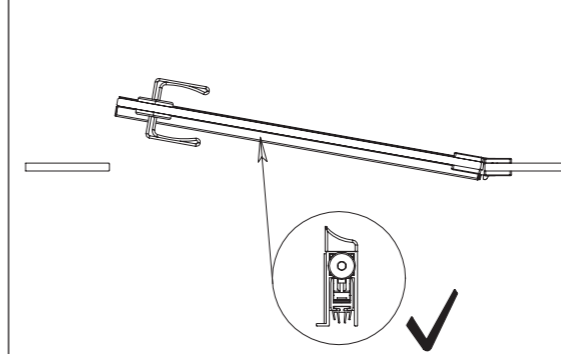

Montaggio corretto
Correct Fitting

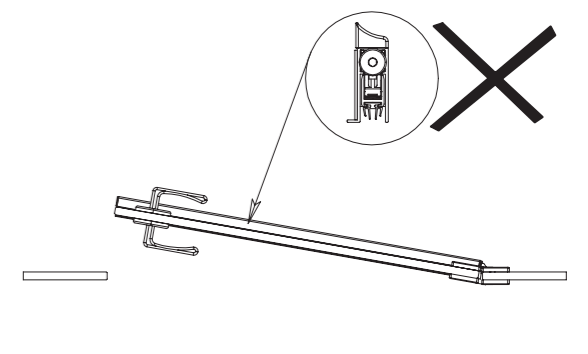

Montaggio errato
Wrong Fitting

3 CORRETTO POSIZIONAMENTO DEL PULSANTE DI SPINTA
CORRECT FITTING OF THE PLUNGER

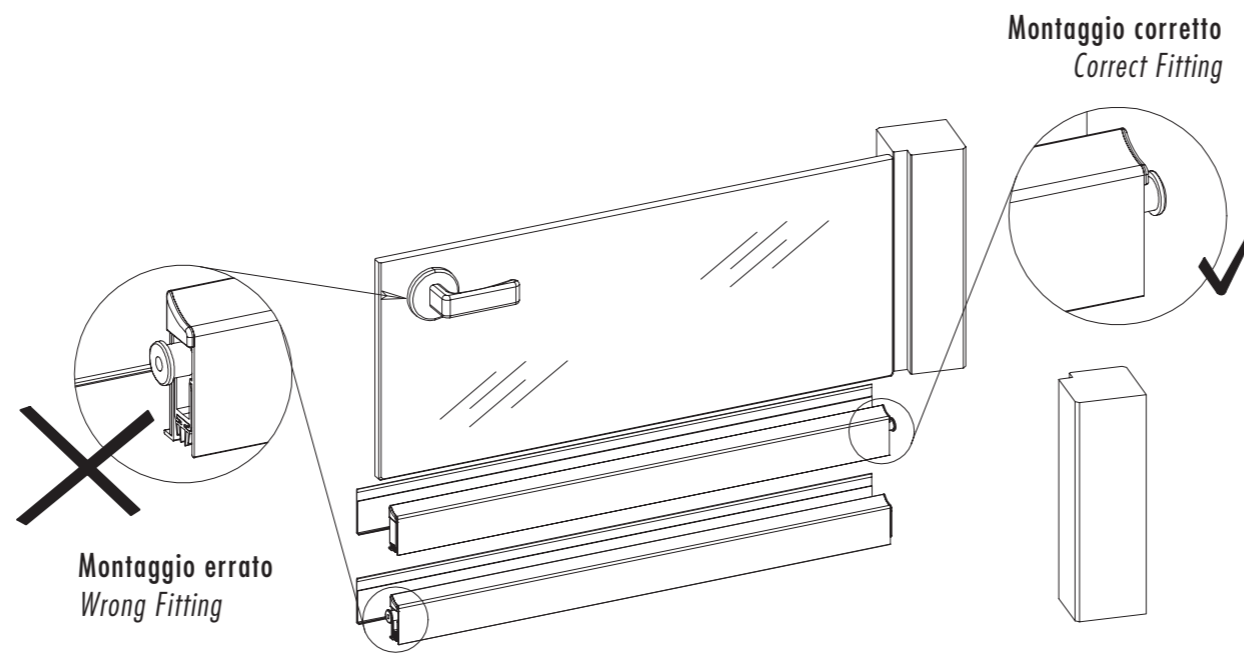

Montaggio errato
Wrong Fitting

Montaggio corretto
Correct Fitting

Vedi al punto 4 la sequenza di reversibilità del pulsante di spinta.
See part 4 for the sequence to reverse plunger.

4 SEQUENZA DI REVERSIBILITÀ DEL PULSANTE DI SPINTA
SEQUENCE TO REVERSE PLUNGER

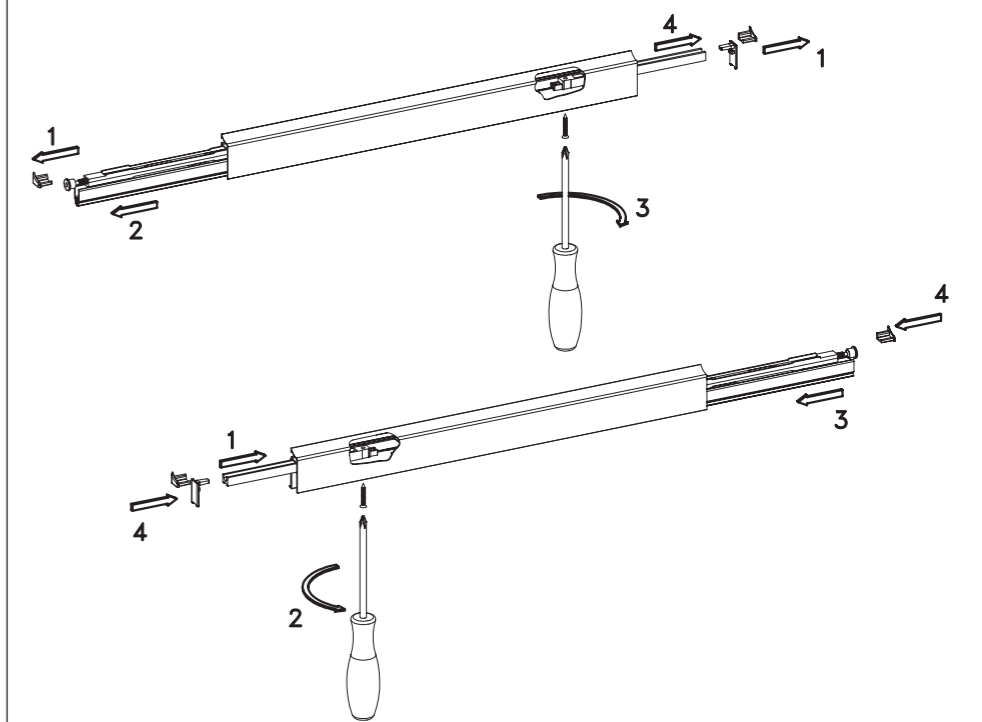

5 REGOLAZIONE DELLA LUNGHEZZA
SU PORTE A BATTENTE CON TELAIO METALLICO
LENGTH ADJUSTMENT ON METAL FRAMED LEAF DOORS

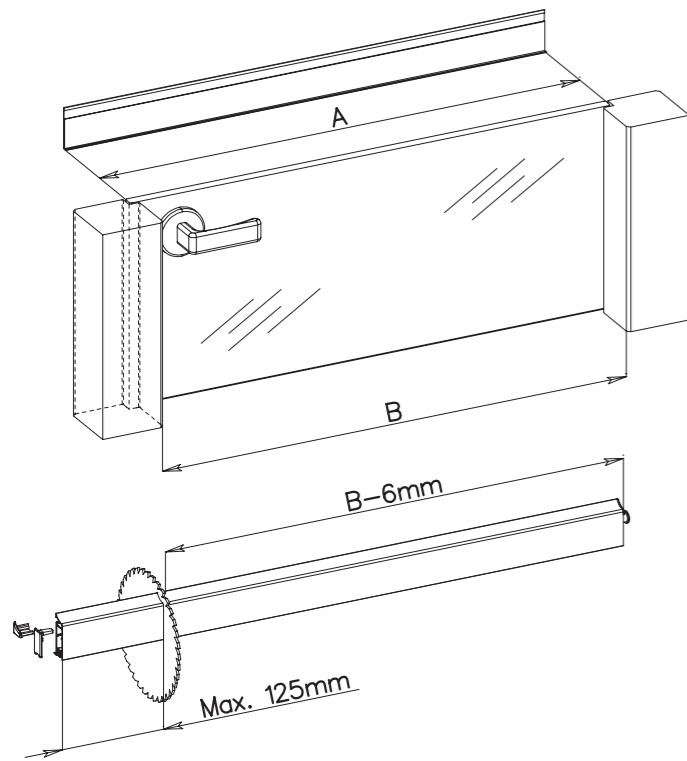

6 REGOLAZIONE DELLA LUNGHEZZA
SU PORTE A BATTENTE SENZA TELAIO
LENGTH ADJUSTMENT ON FRAMELESS LEAF DOORS

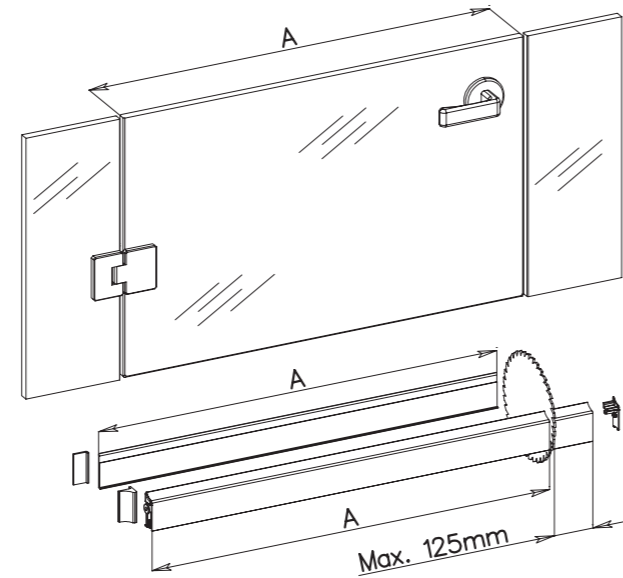

7 MONTAGGIO DELLA GUARNIZIONE AUTOMATICA
DOOR BOTTOM FITTING

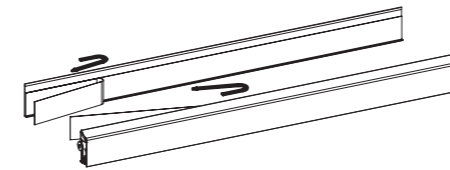

Togliere il liner dall'adesivo
Detach the liner from adhesive tape

Pulire con cura il vetro
Clean the glass with care

Applicare i profili, allineandosi con il dentello di riferimento
Apply profiles, in line with the reference mark

Esercitare una discreta pressione sui profili per garantirne un perfetto incollaggio
Apply the necessary pressure on the profiles to ensure perfect bonding

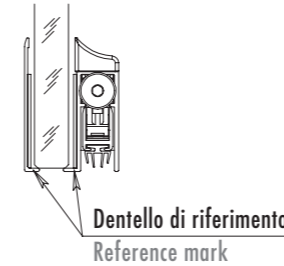

Dentello di riferimento
Reference mark



Non usare detersivi o soluzioni a base di sapone.
Do not use soap-based cleanser.



Pulire esclusivamente con solventi a base di alcool isopropilico. Cod: GLASSCLEAN
Use exclusively isopropyl alcohol cleaning wipes. Cod: GLASSCLEAN

8 MONTAGGIO DEL KIT ATTUATORE SU PORTA SENZA TELAIO
ACTIVATING KIT FITTING ON FRAMELESS LEAF DOORS

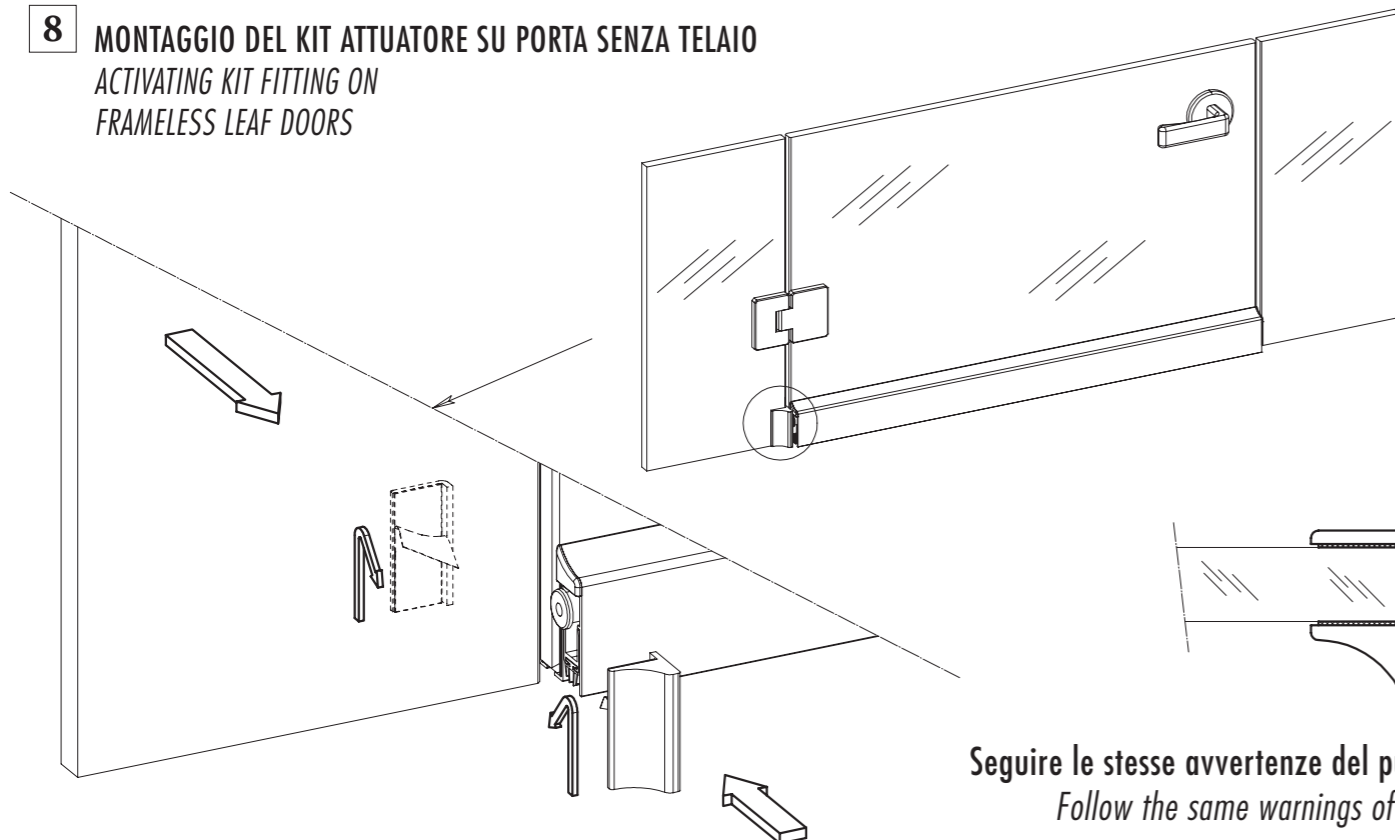

Seguire le stesse avvertenze del punto 7
Follow the same warnings of part 7

9 REGOLAZIONE DELLA CORSA DELLA GUARNIZIONE AUTOMATICA
ADJUSTING THE DOOR BOTTOM MAXIMUM DROP

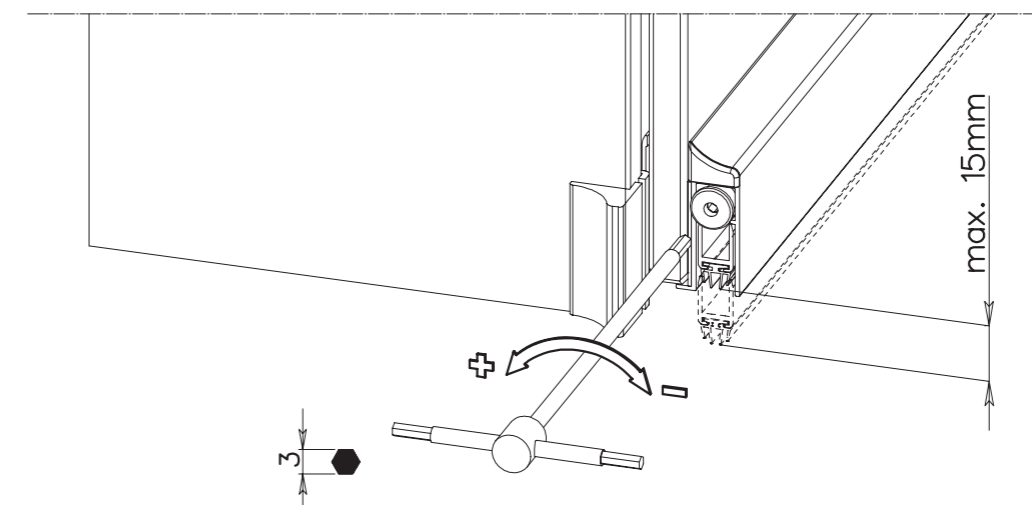

Agendo sul pulsante di spinta si regola la corsa / pressione della guarnizione
Rotate the plunger to adjust the maximum drop / pressure of the seal

Svitando (senso antiorario) si aumenta la corsa
Unscrewing (counterclockwise) the drop increases

Avvitando (senso orario) si diminuisce la corsa
Screwing (clockwise) the drop decreases