

Istruzioni per il montaggio
Instructions for the assembly
Instructions de montage
Anweisungen für den zusammenbau
Instrucciones para el montaje

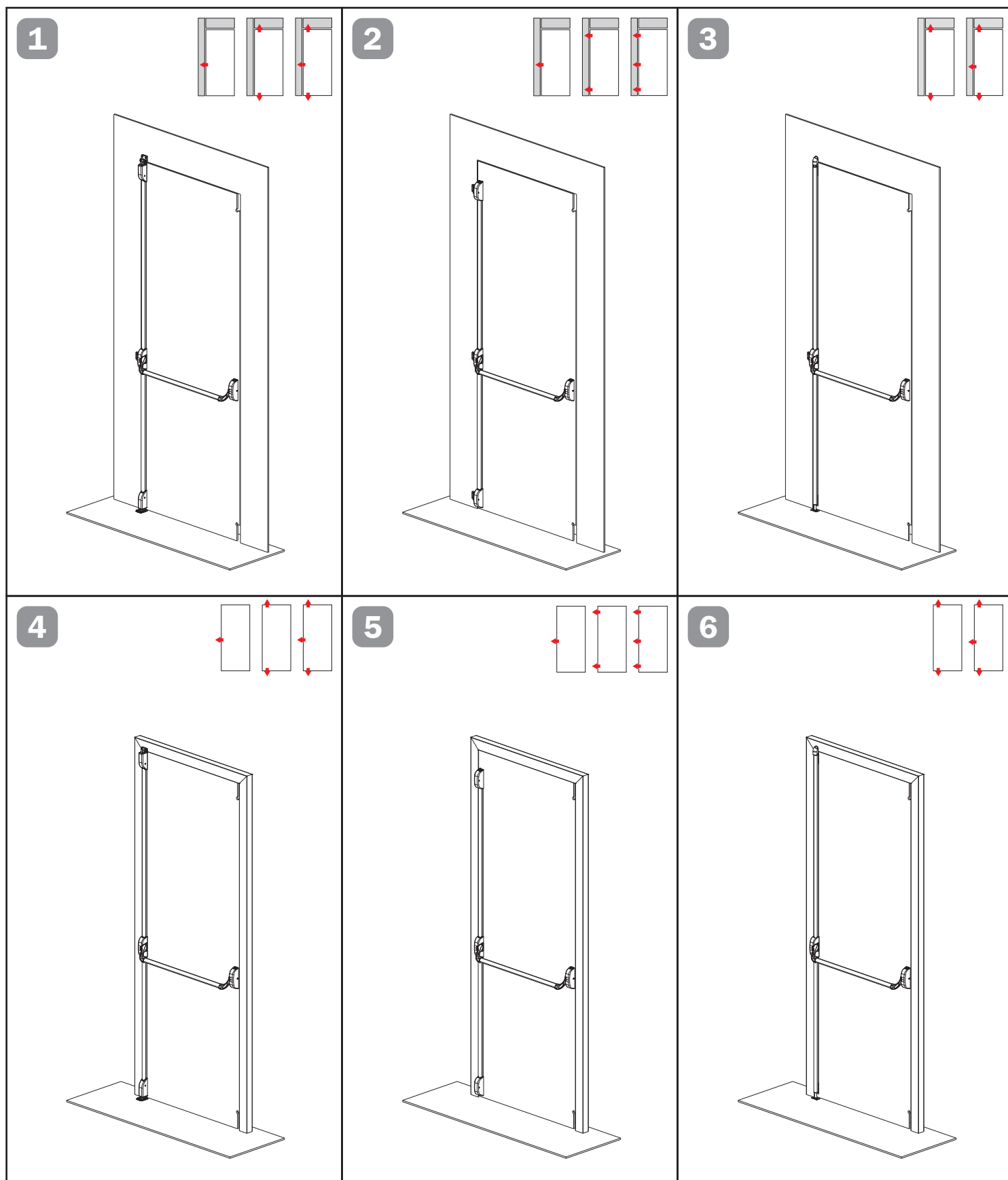

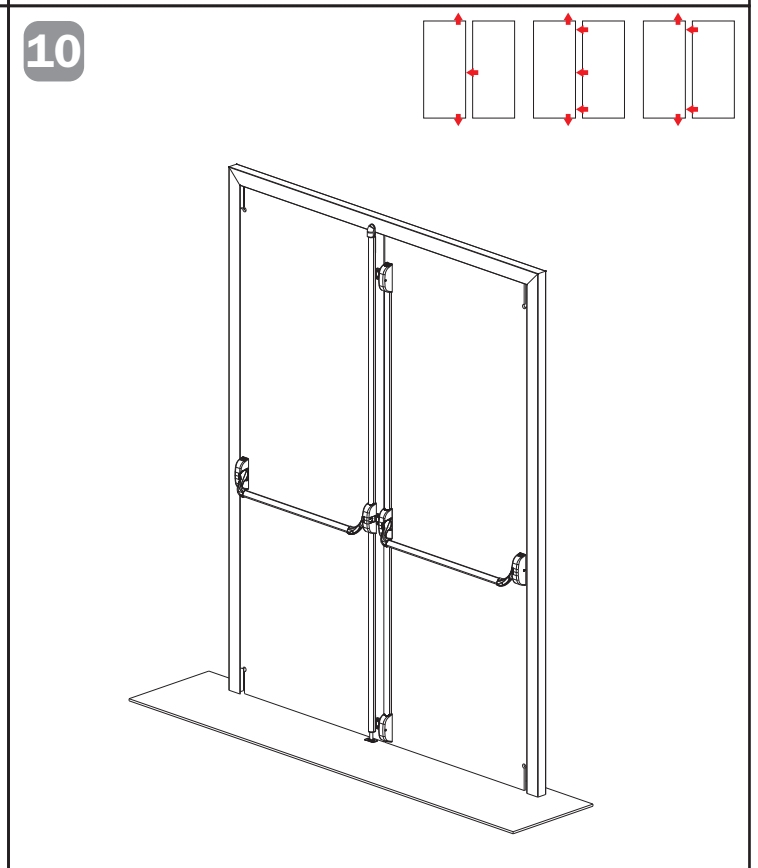
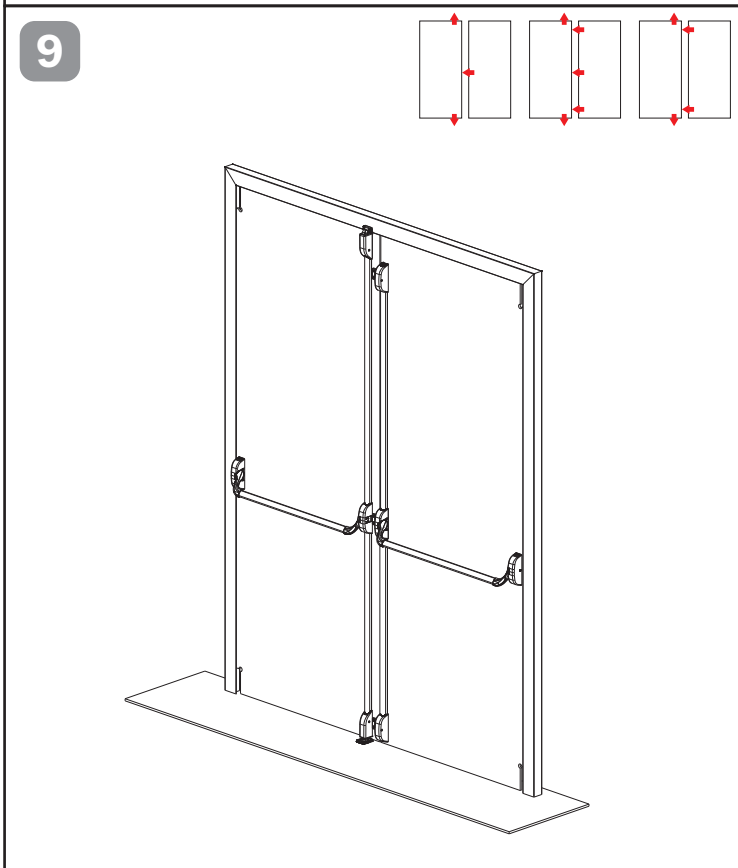
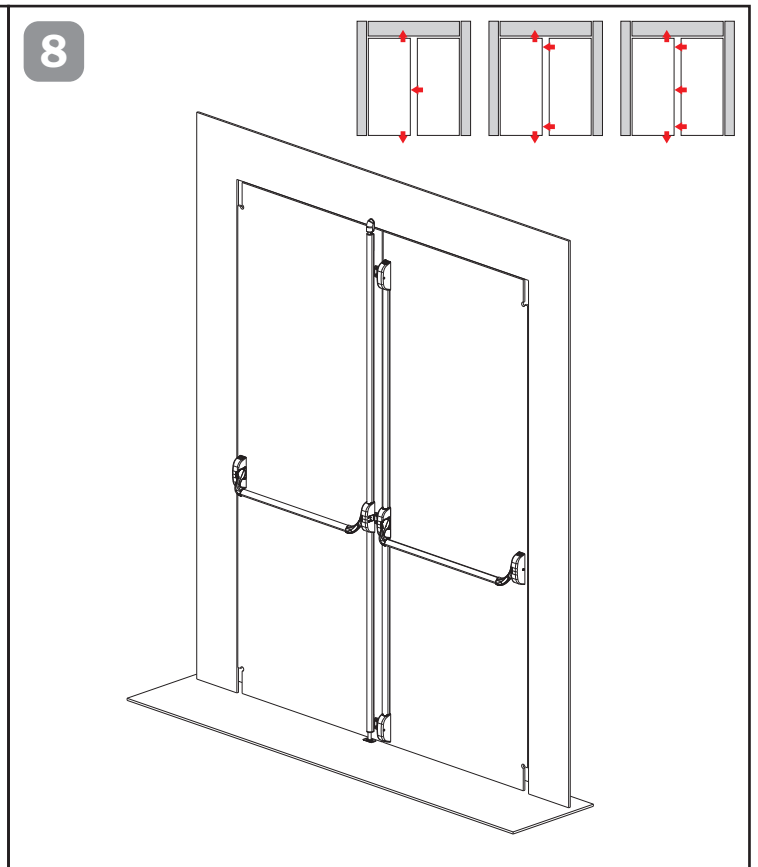
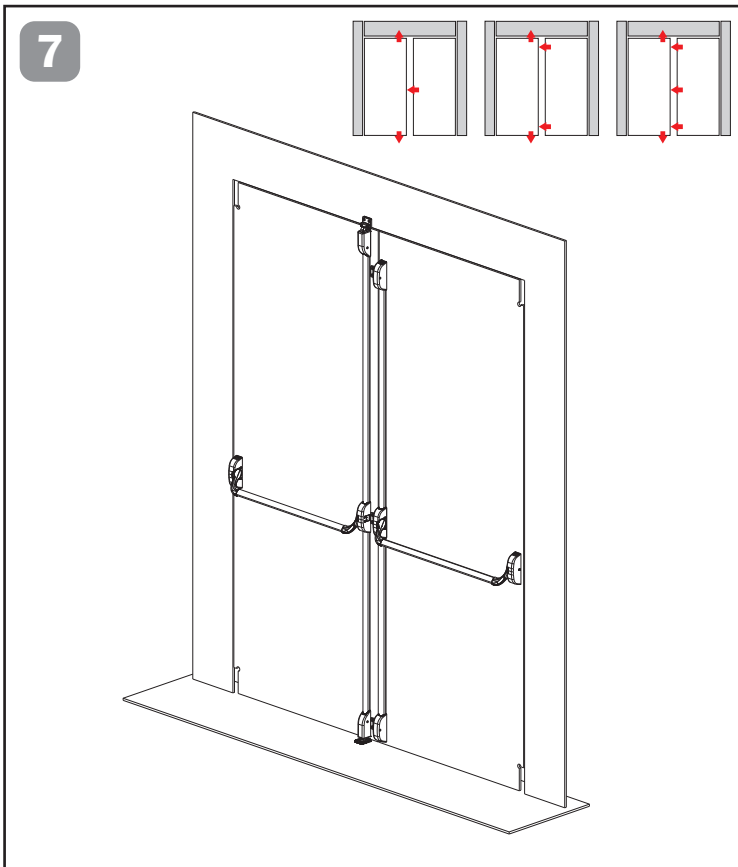

ATTENZIONE: nel seguente manuale sono state prese in considerazione le configurazioni più comuni; altre configurazioni richiedono una verifica delle quote di foratura. Le quote di foratura indicate nelle pagine seguenti, sono state calcolate con distanze tra anta e telaio definite dalla quota (L). Nel caso tale quota fosse differente, tutte le altre quote devono essere ricalcolate. Iseo Serrature non si assume nessuna responsabilità nel caso di forature errate.

NOTE: in this manual the most common configurations have been taken into consideration; for other configurations the height of the drilling must be checked. The height of the drilling shown in the following pages has been calculated on the basis of the distances between the leaf and the frame defined by height (L). If this height should differ, all the other heights must be recalculated. Iseo Serrature cannot be held responsible in any way for incorrect drilling.

ATTENTION : les configurations décrites dans ce manuel sont celles le plus communément utilisées. D'autres configurations nécessitent d'un contrôle des valeurs de perçage. Les valeurs de perçage indiquées dans les pages suivantes ont été calculées sur la base de distances battant-cadre définies par la valeur (L). Au cas où cette valeur serait différente, toutes les autres valeurs devront être recalculées. Iseo Serrature dégage toute responsabilité en cas de perçages erronés.

ACHTUNG: im folgenden Handbuch werden die üblichsten Konfigurationen berücksichtigt; andere Konfigurationen erfordern eine Überprüfung der Bohrlochmaße. Die auf den folgenden Seiten angegebenen Bohrlochmaße wurden mit als (L) bezeichneten Abständen zwischen Flügel und Rahmen berechnet. Falls das Maß abweichen sollte, müssen alle anderen Maße neu berechnet werden. Iseo Serrature übernimmt keine Verantwortung bei falschen Bohrlochern.

ATENCIÓN: en el manual siguiente se han tomado en consideración las configuraciones más corrientes; para otras configuraciones se necesita comprobar las cotas de perforación. Las cotas de perforación que se indican en las páginas siguientes se han calculado con distancias entre la hoja y el marco definidas por la cota (L): En caso de que dicha cota fuera diferentes, deberán calcularse nuevamente todas las demás cotas. Iseo Serrature se exime de toda responsabilidad en caso de perforación errónea.

1

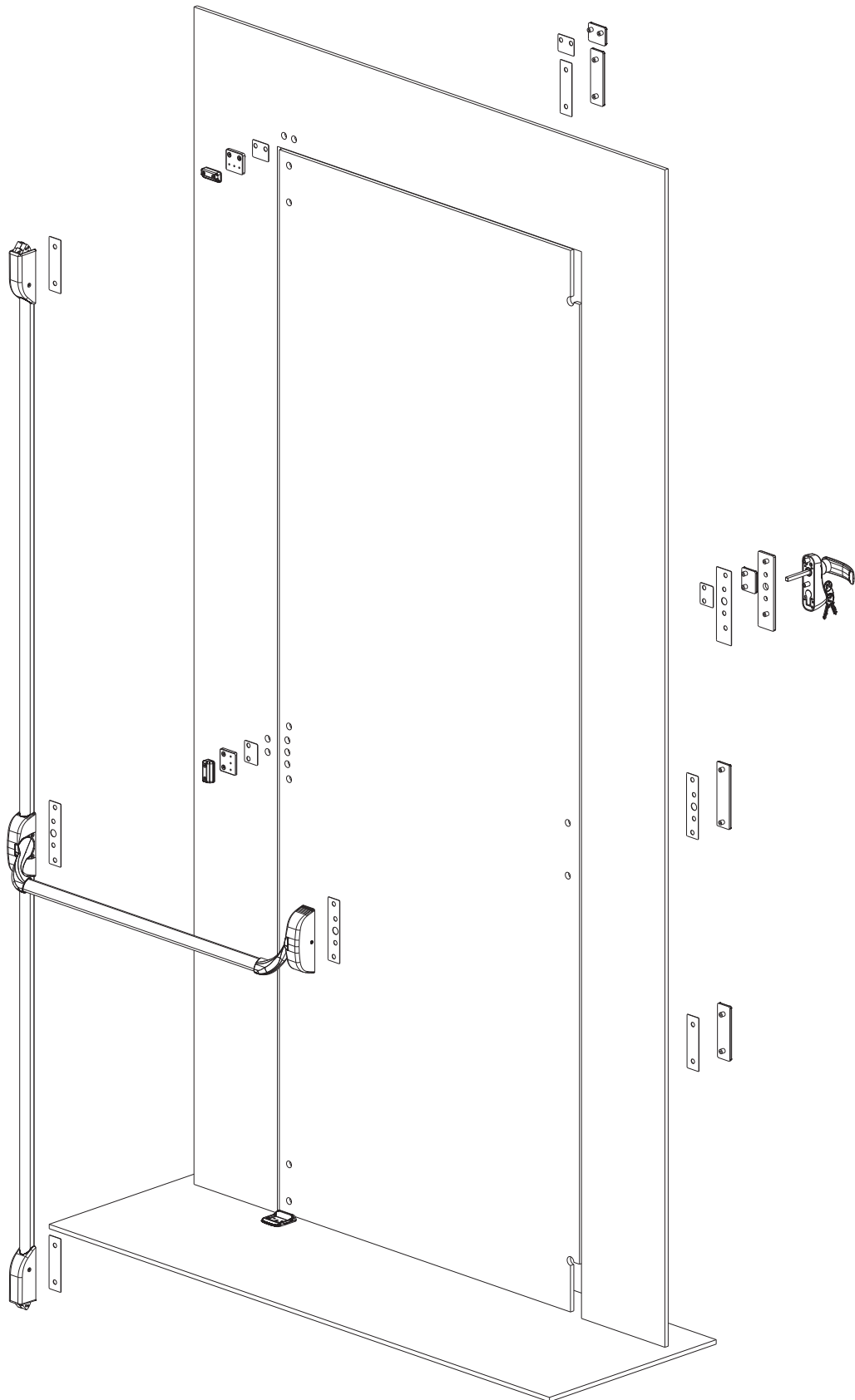
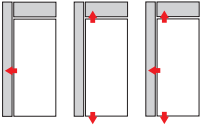

1b

A

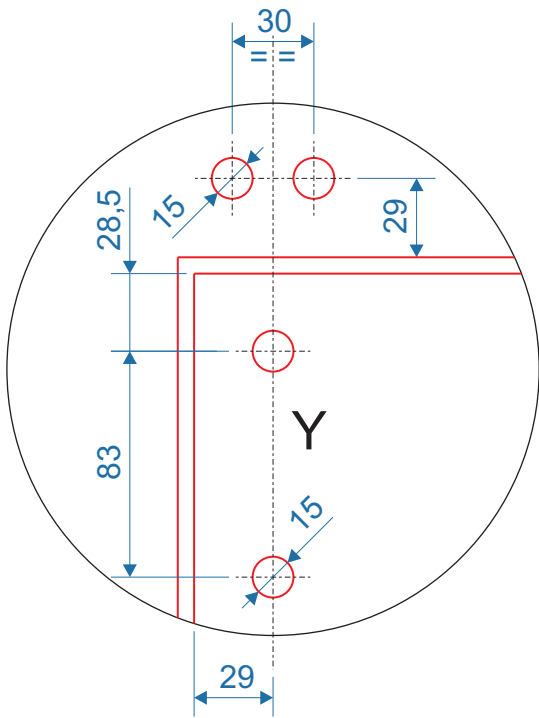

B

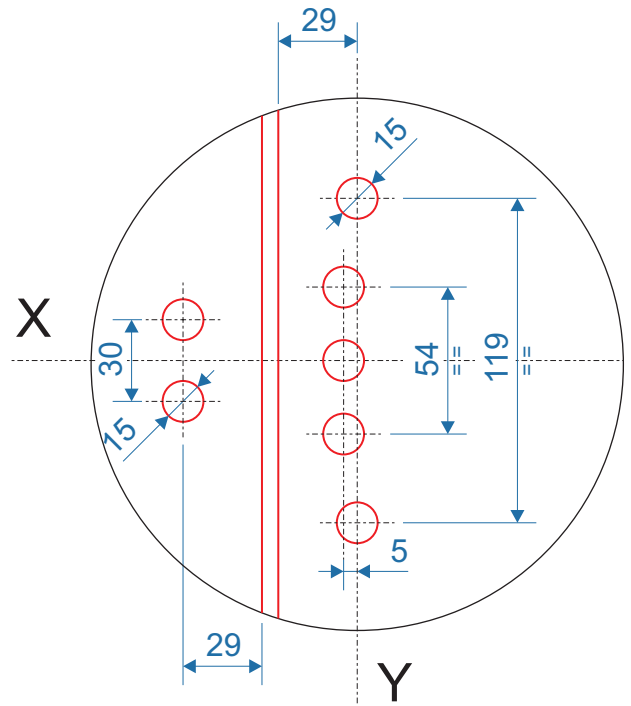

C

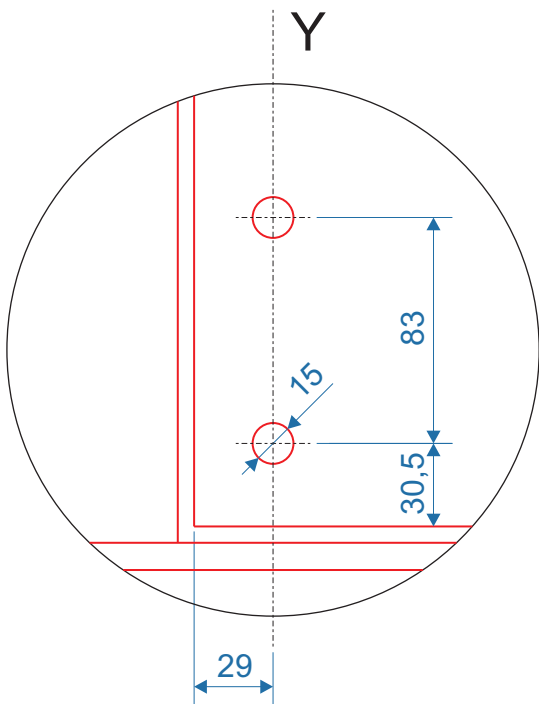

D

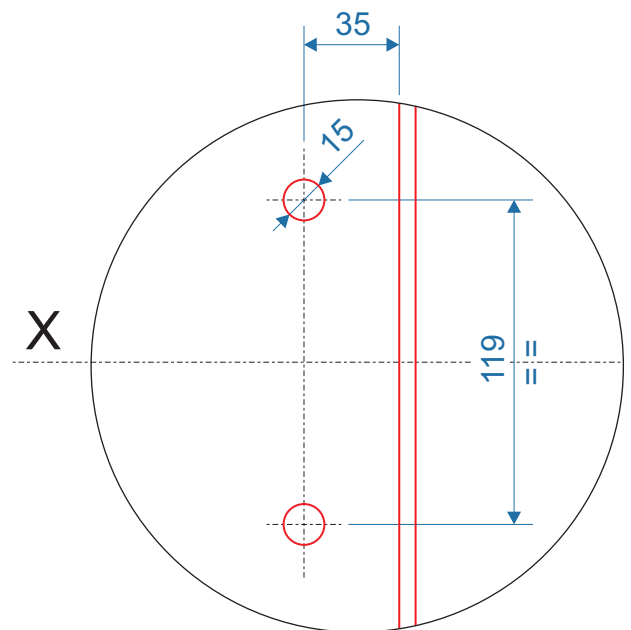

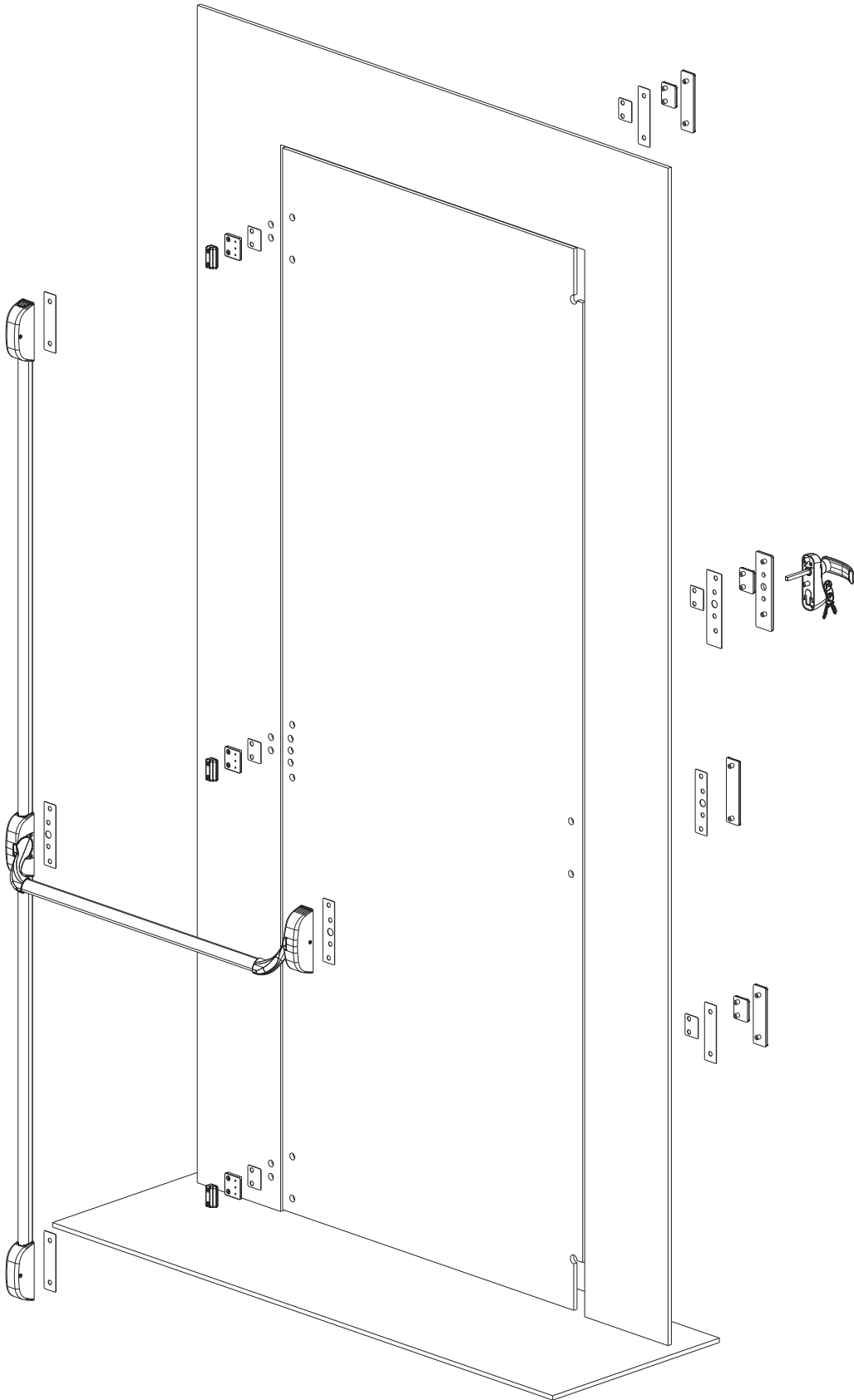
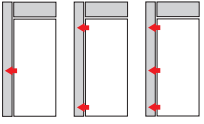

2a

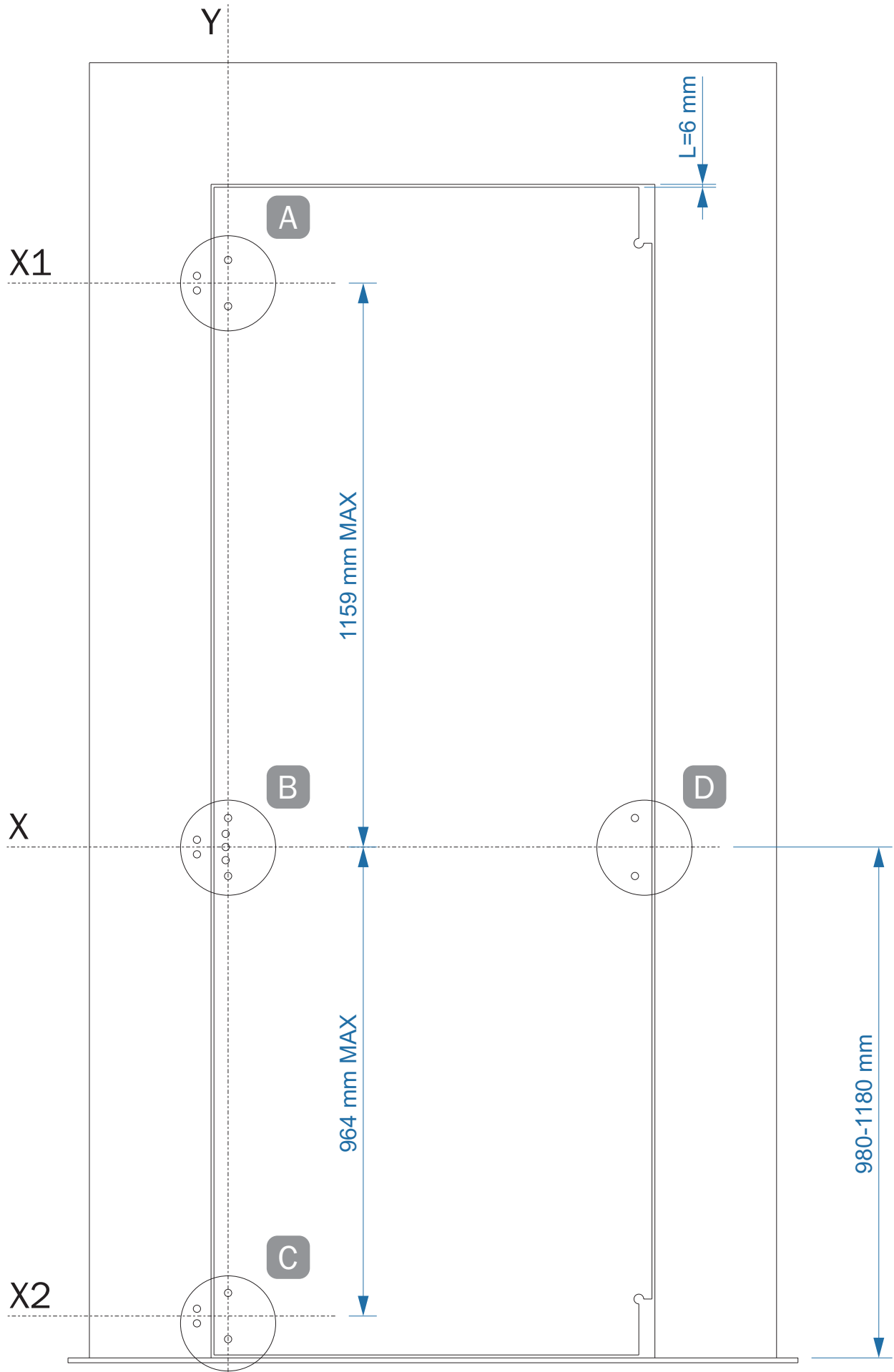

2b

A

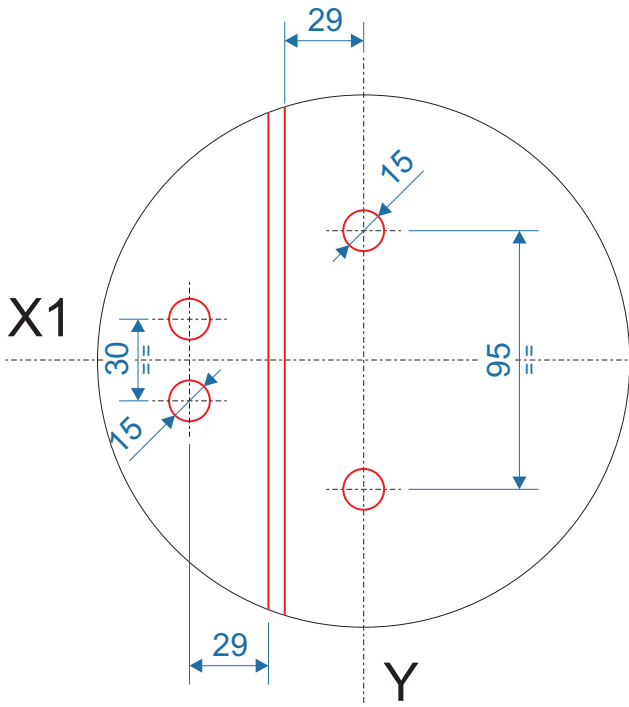

B

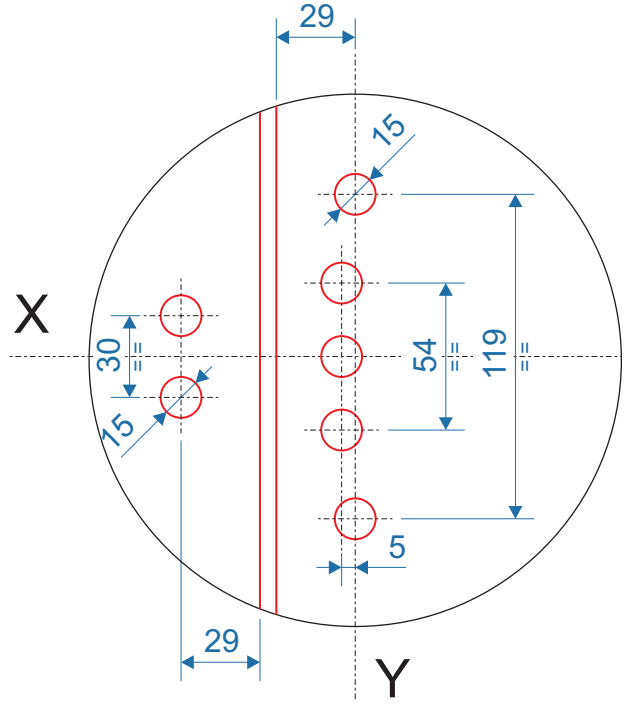

C

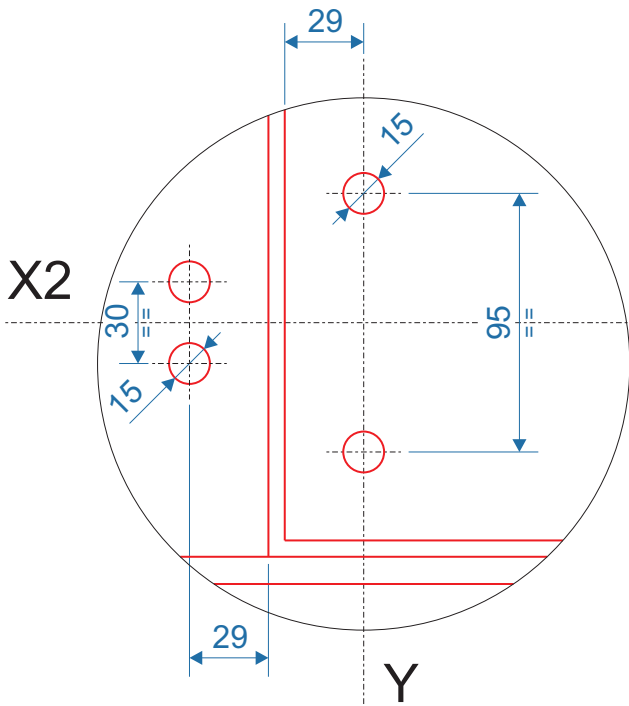

D

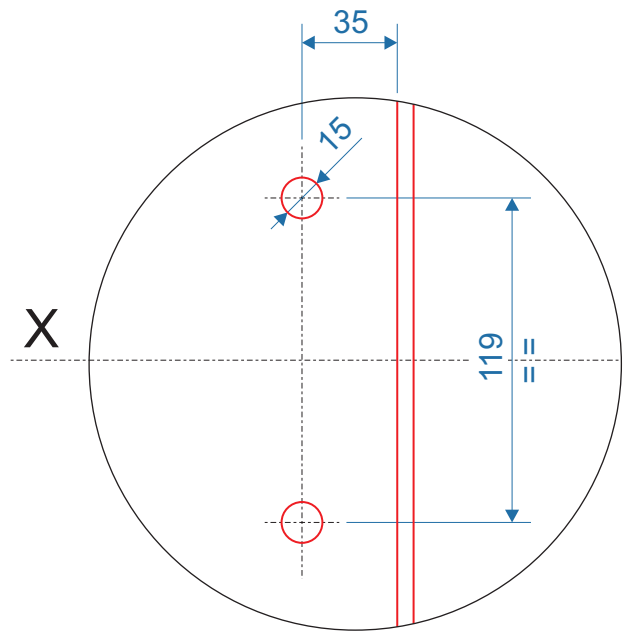

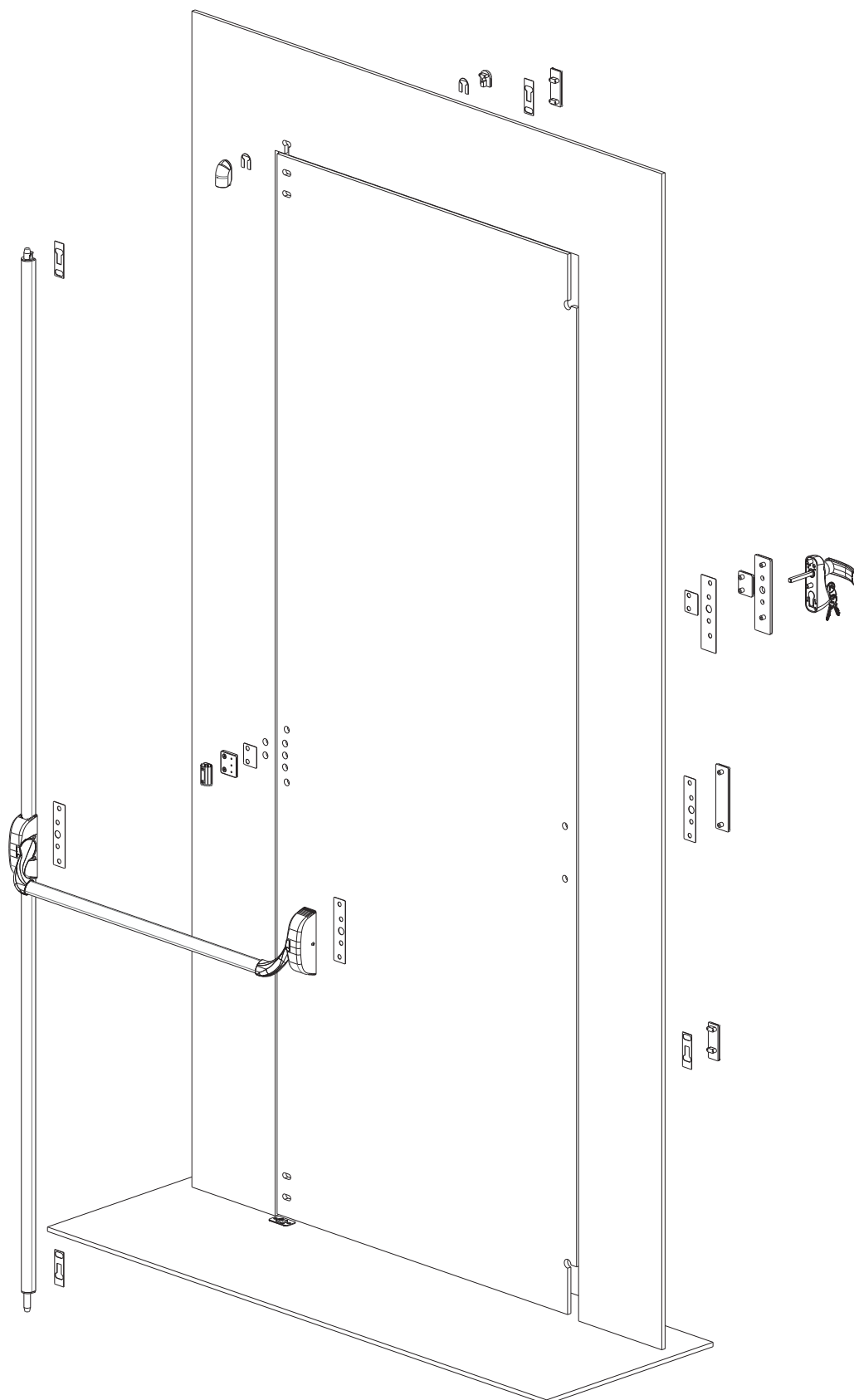
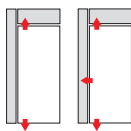

3a

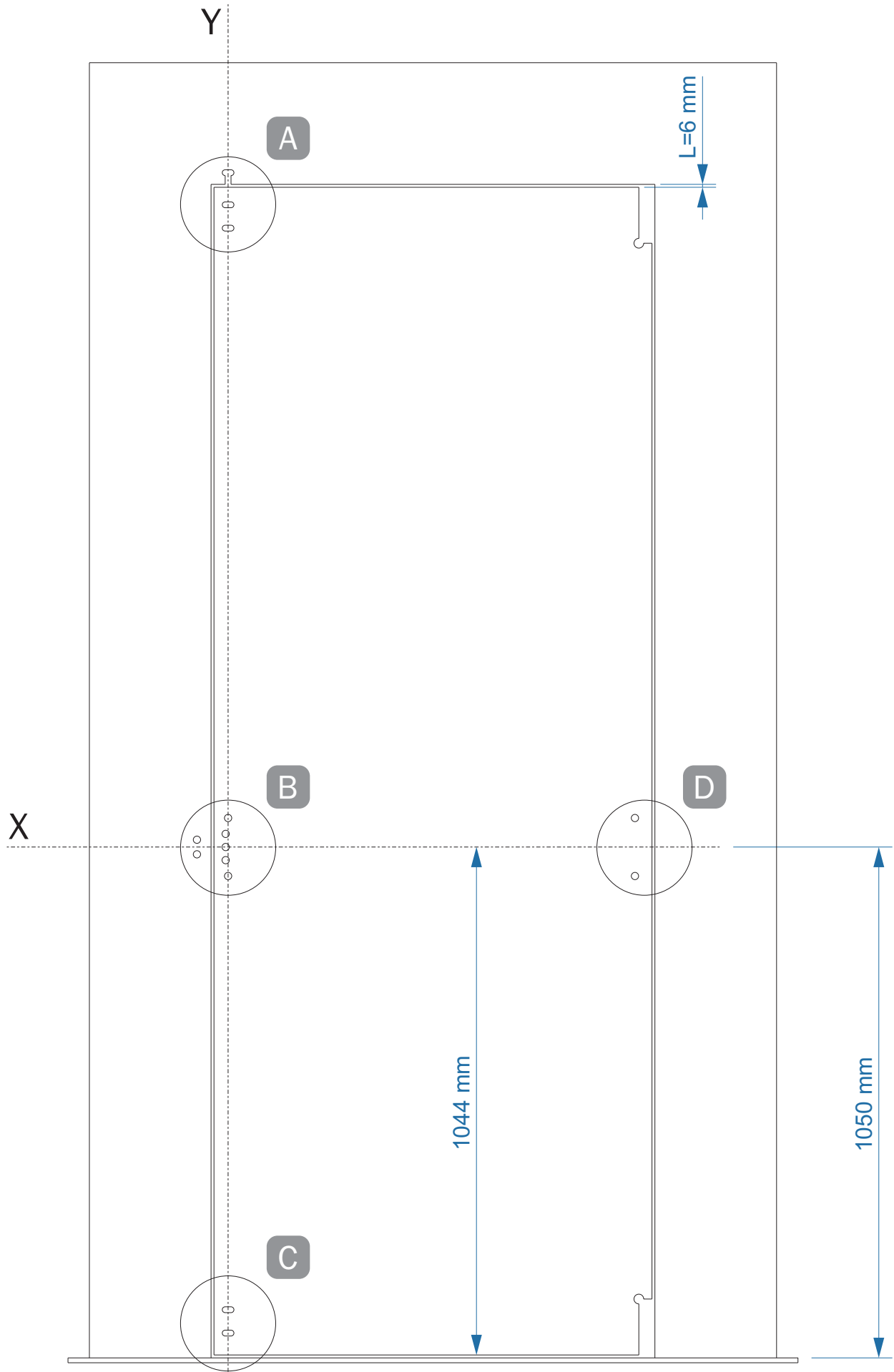

4

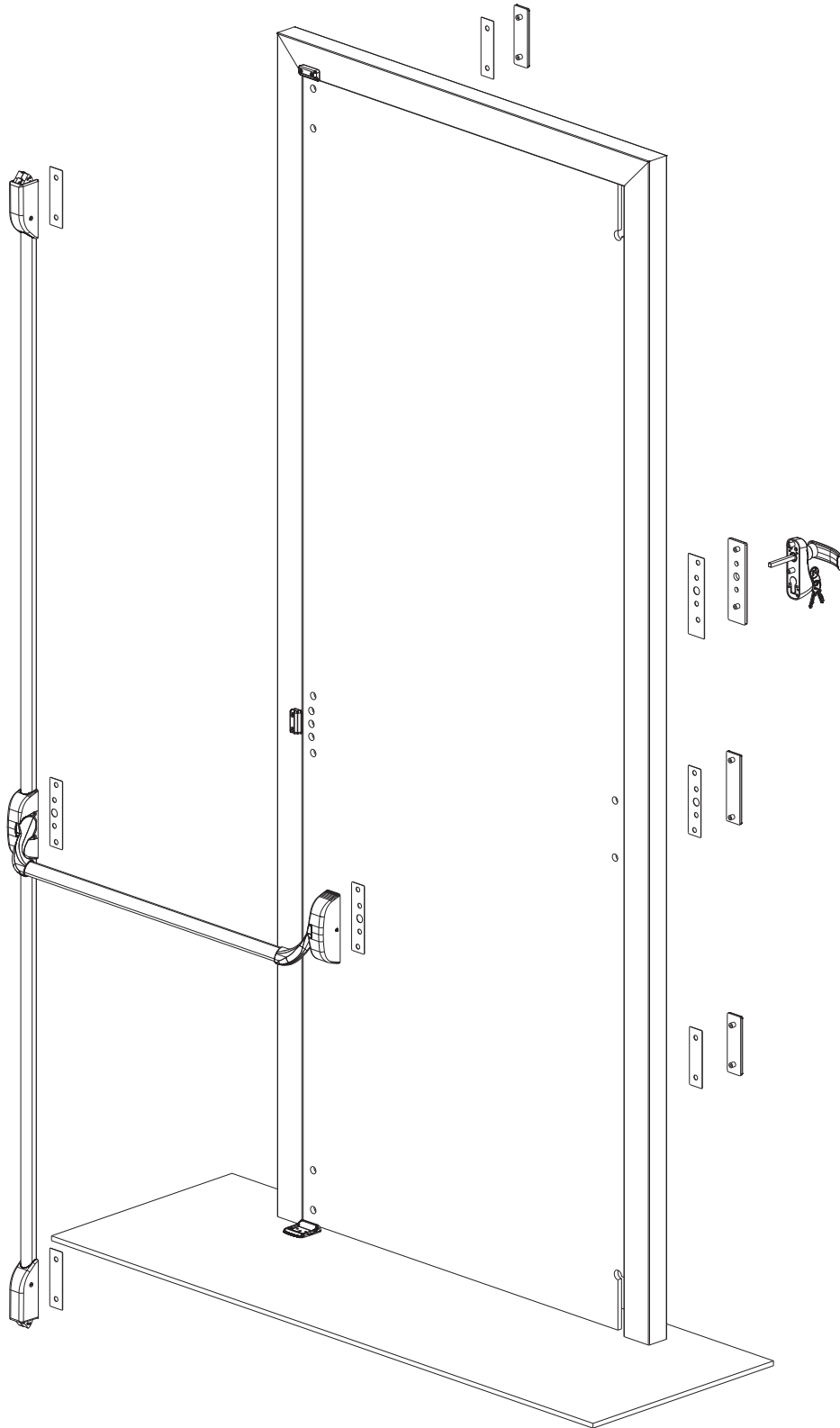
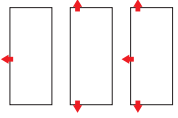

4a

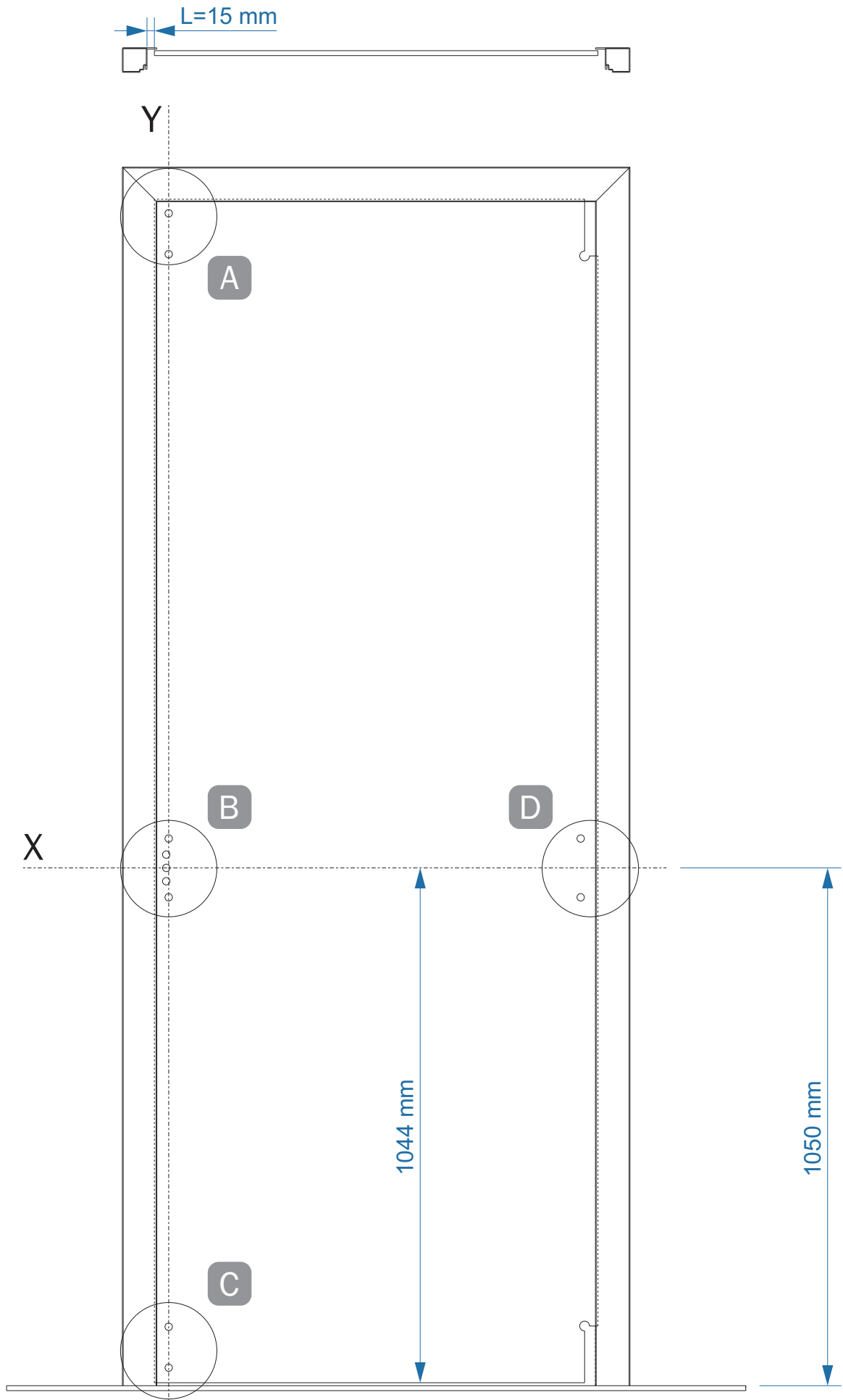

4b

A

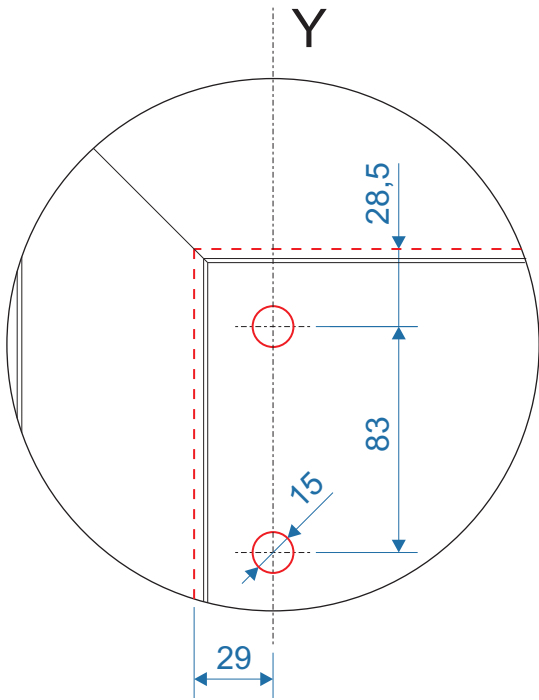

B

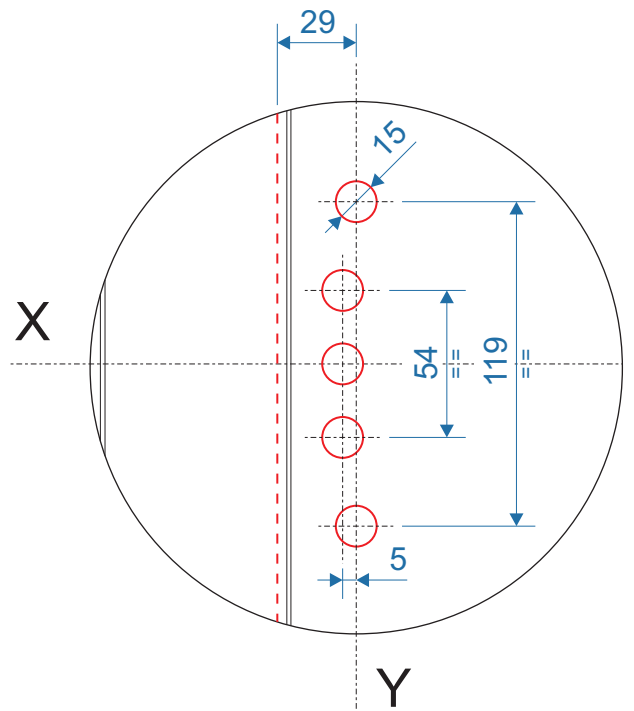

C

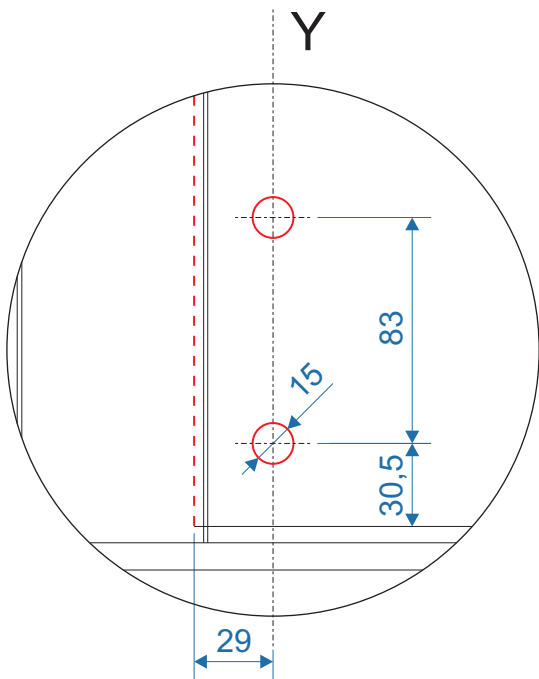

D

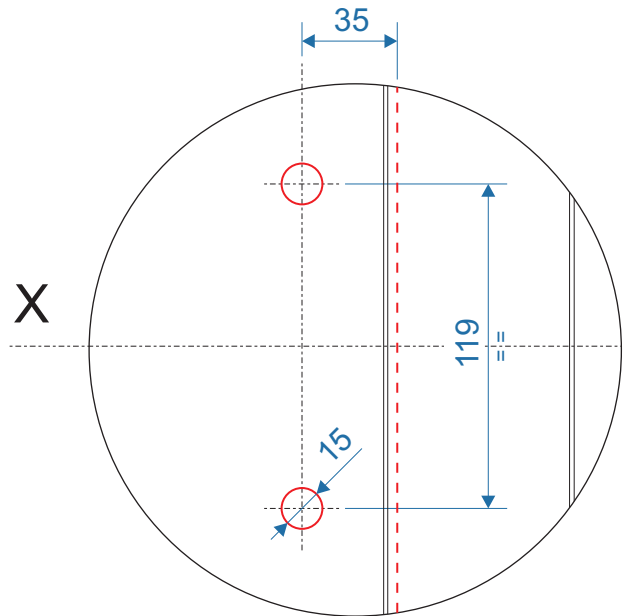

5

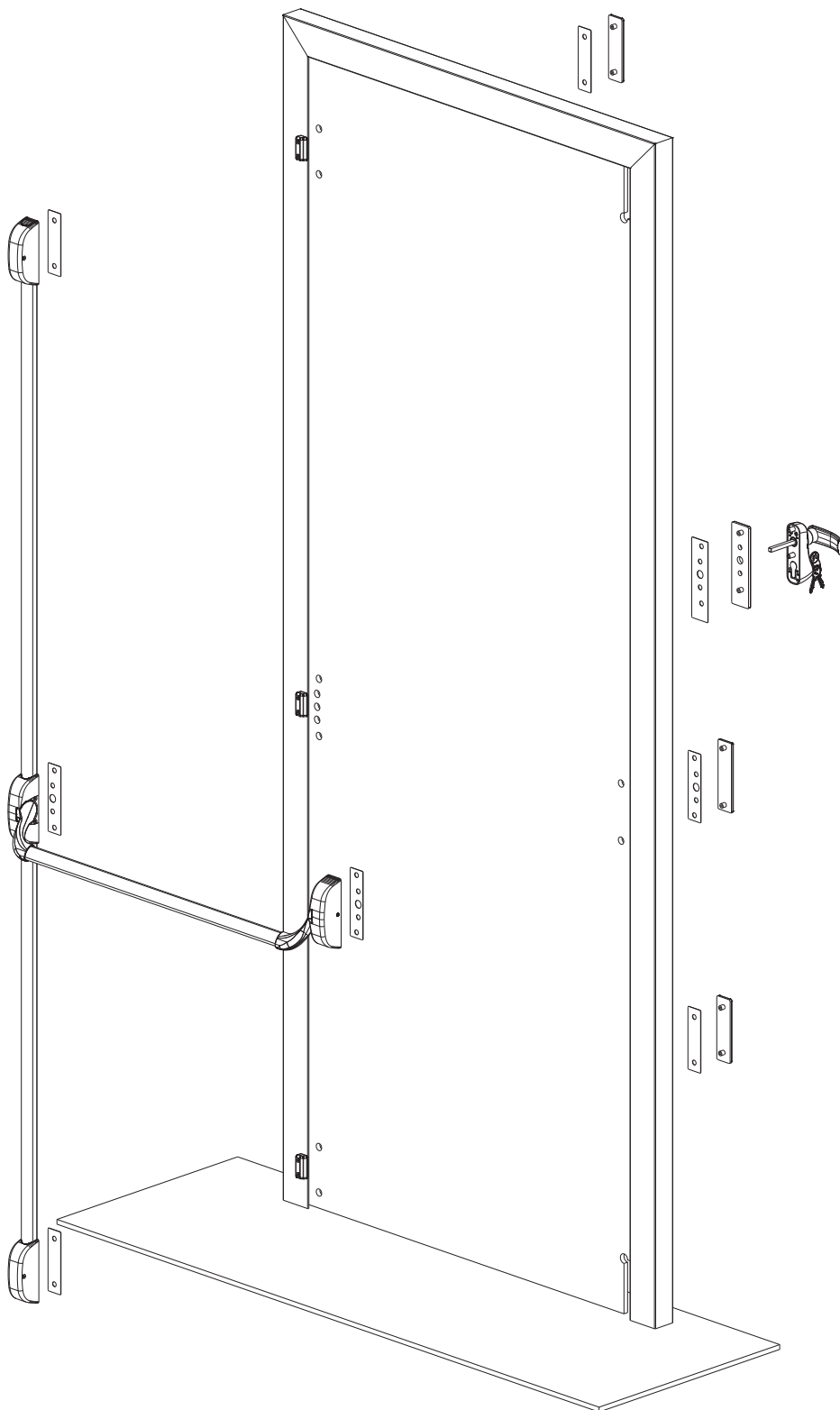
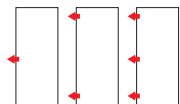

5a

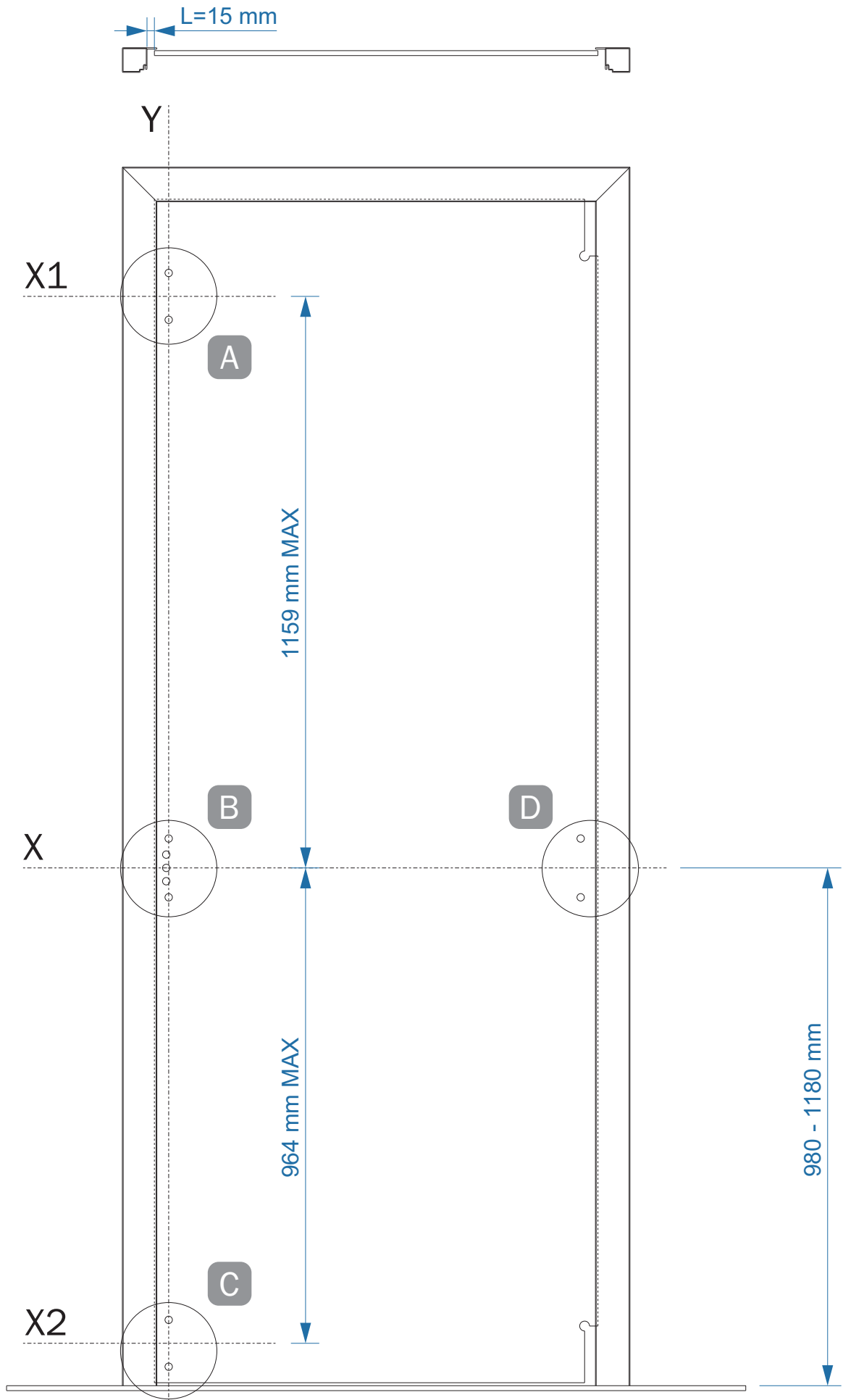

5b

A

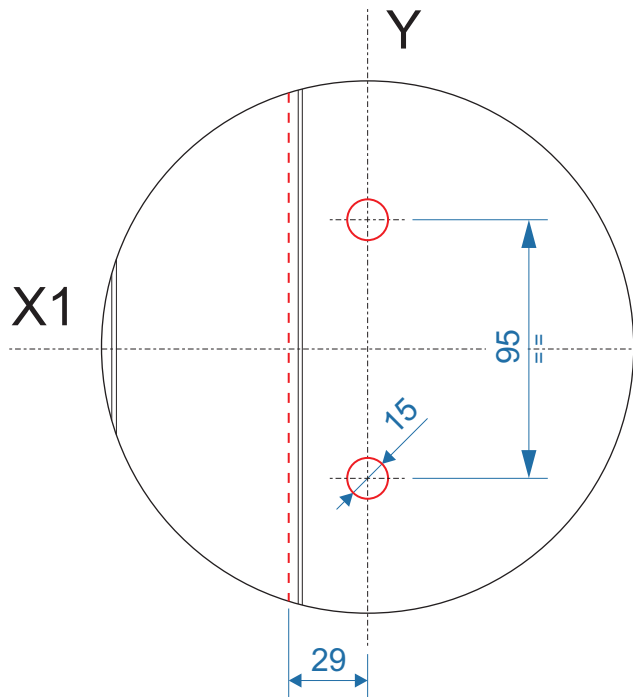

B

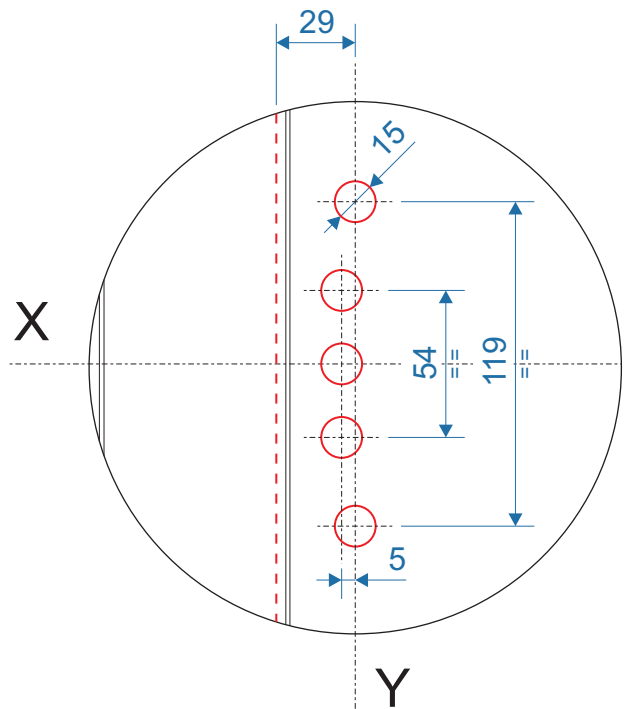

C

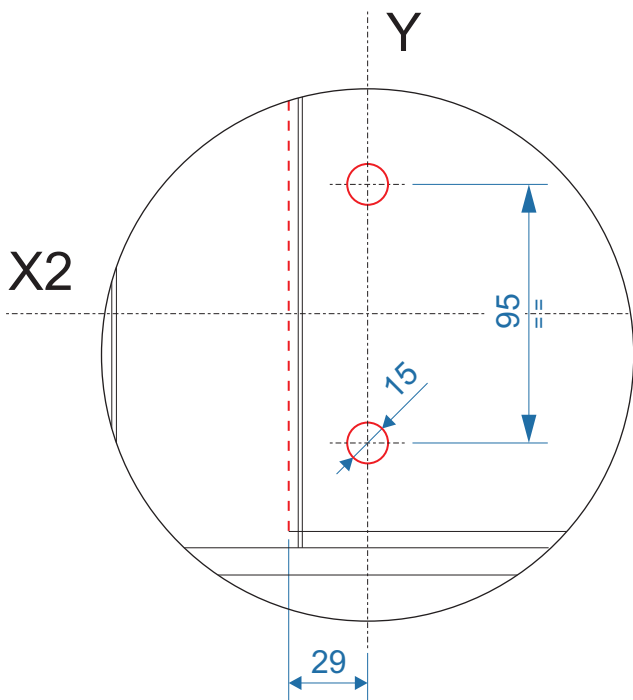

D

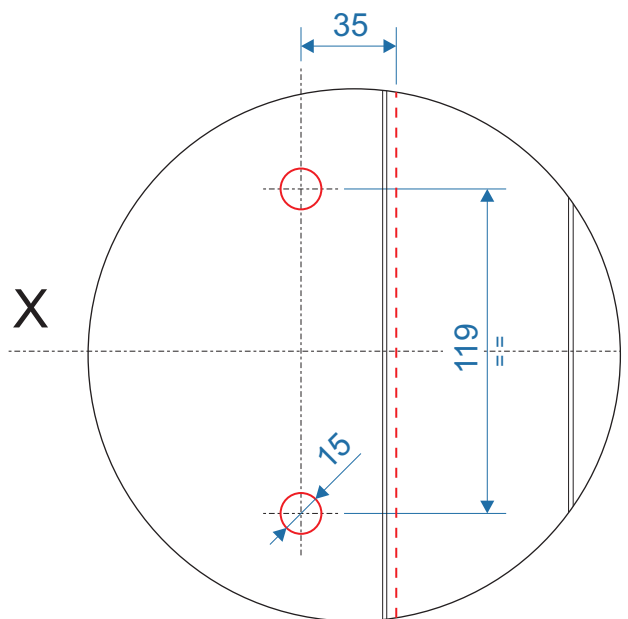

6

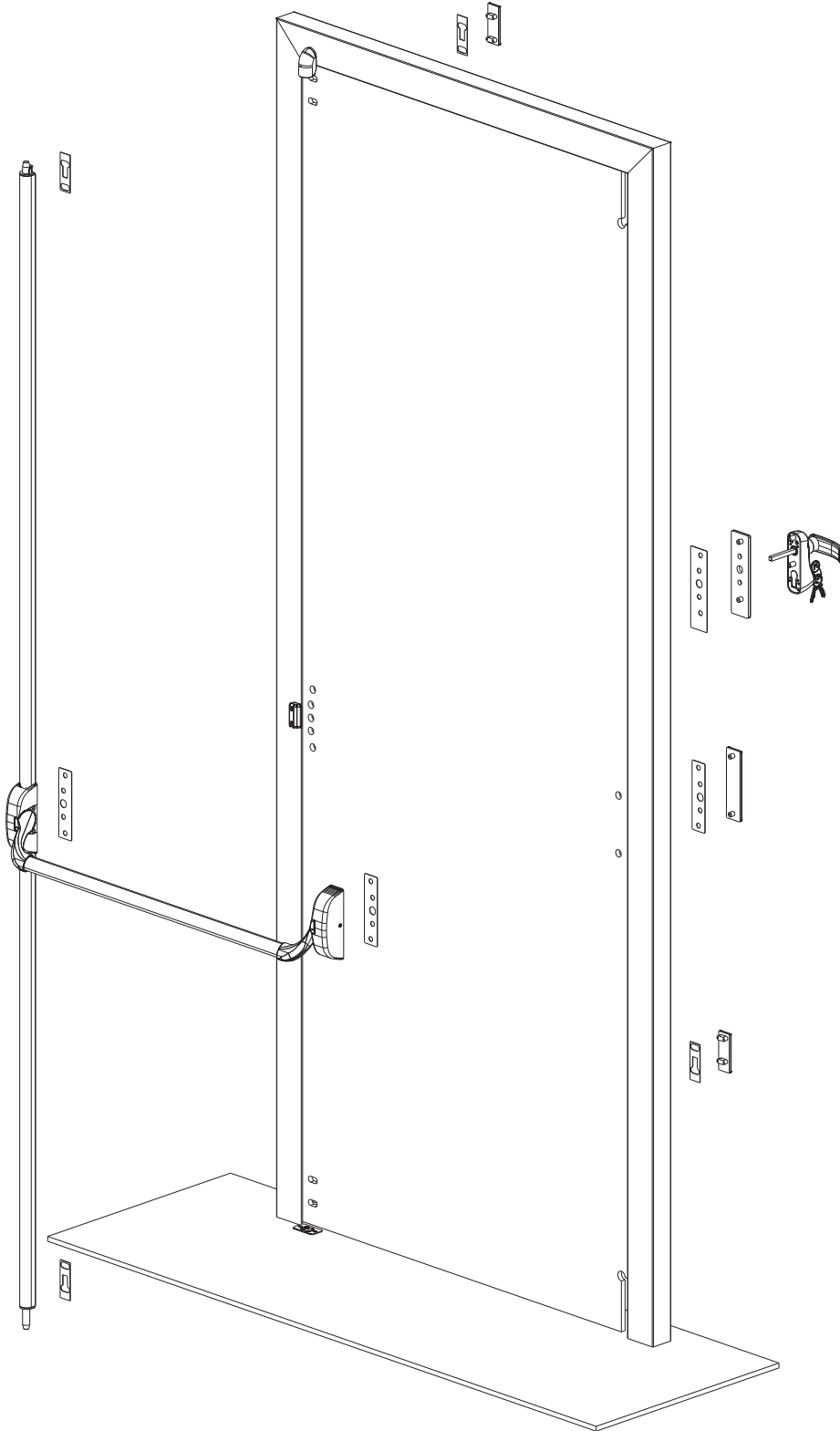
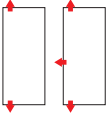

6a

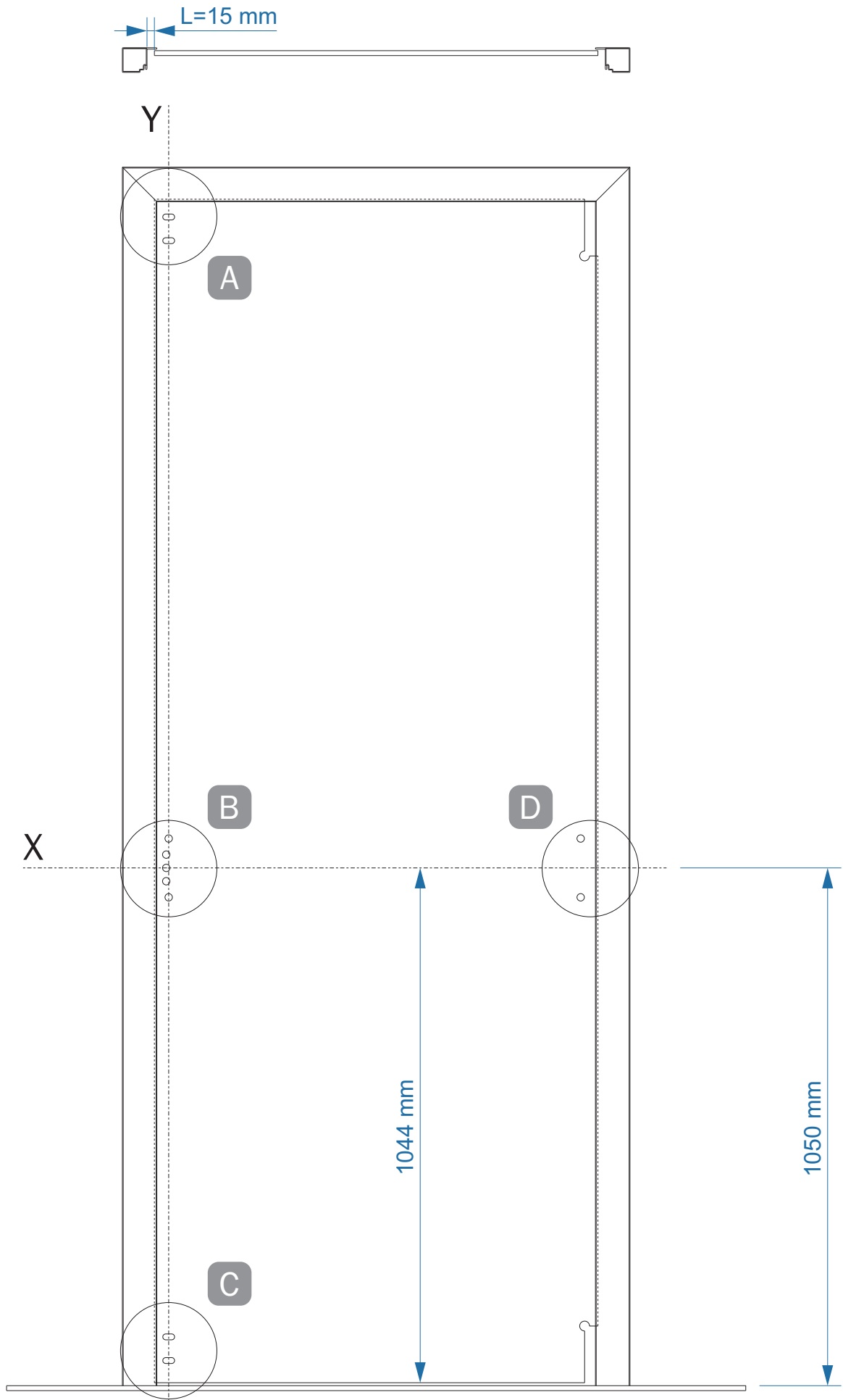

6b

A

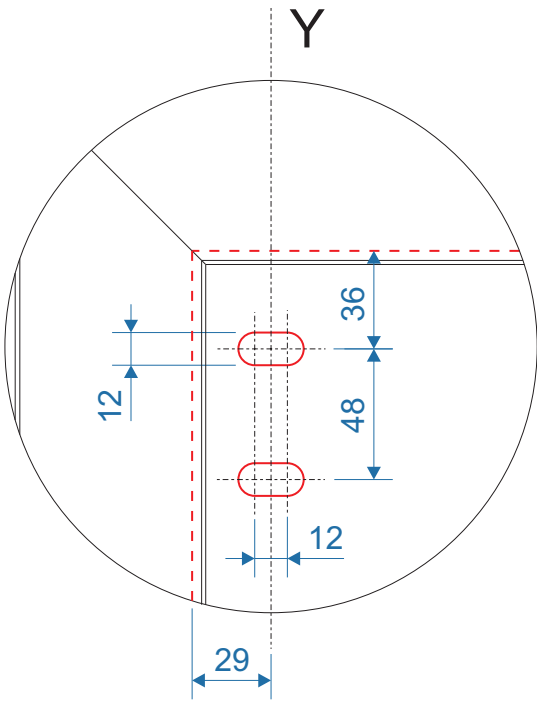

B

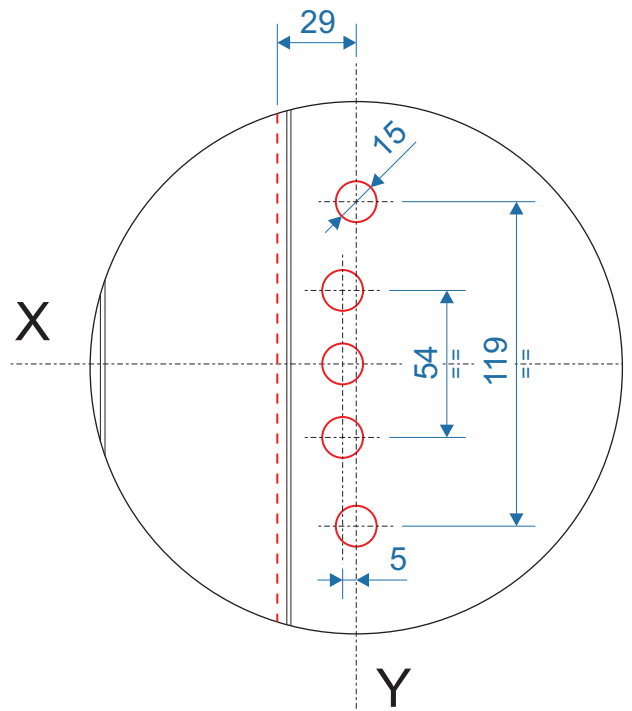

C

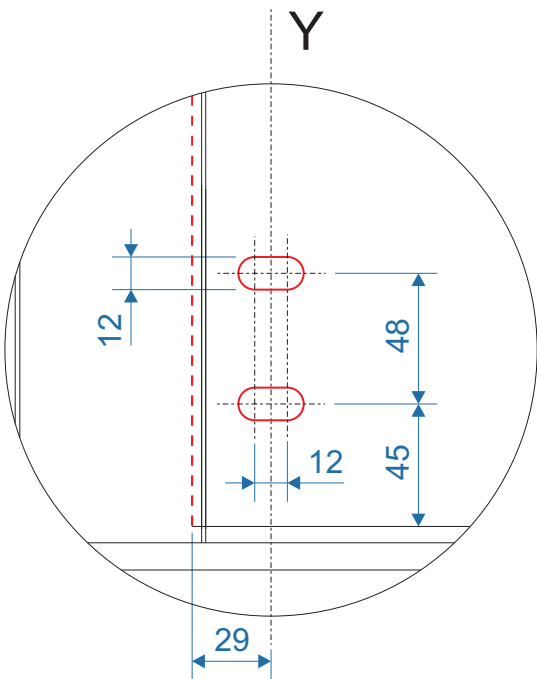

D

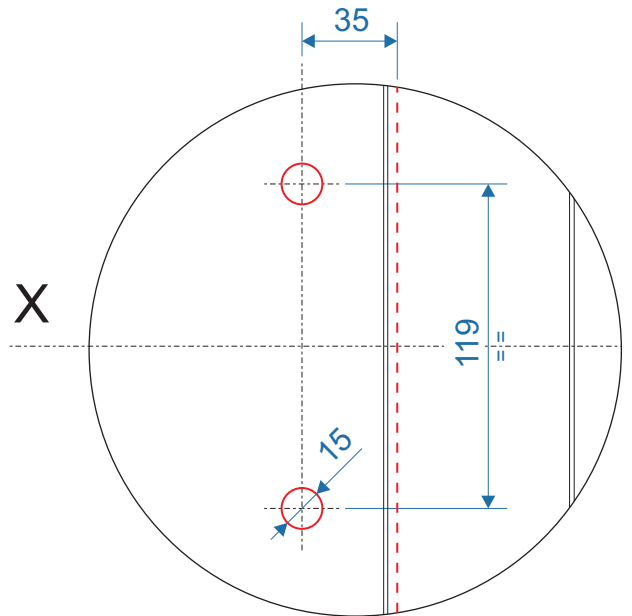

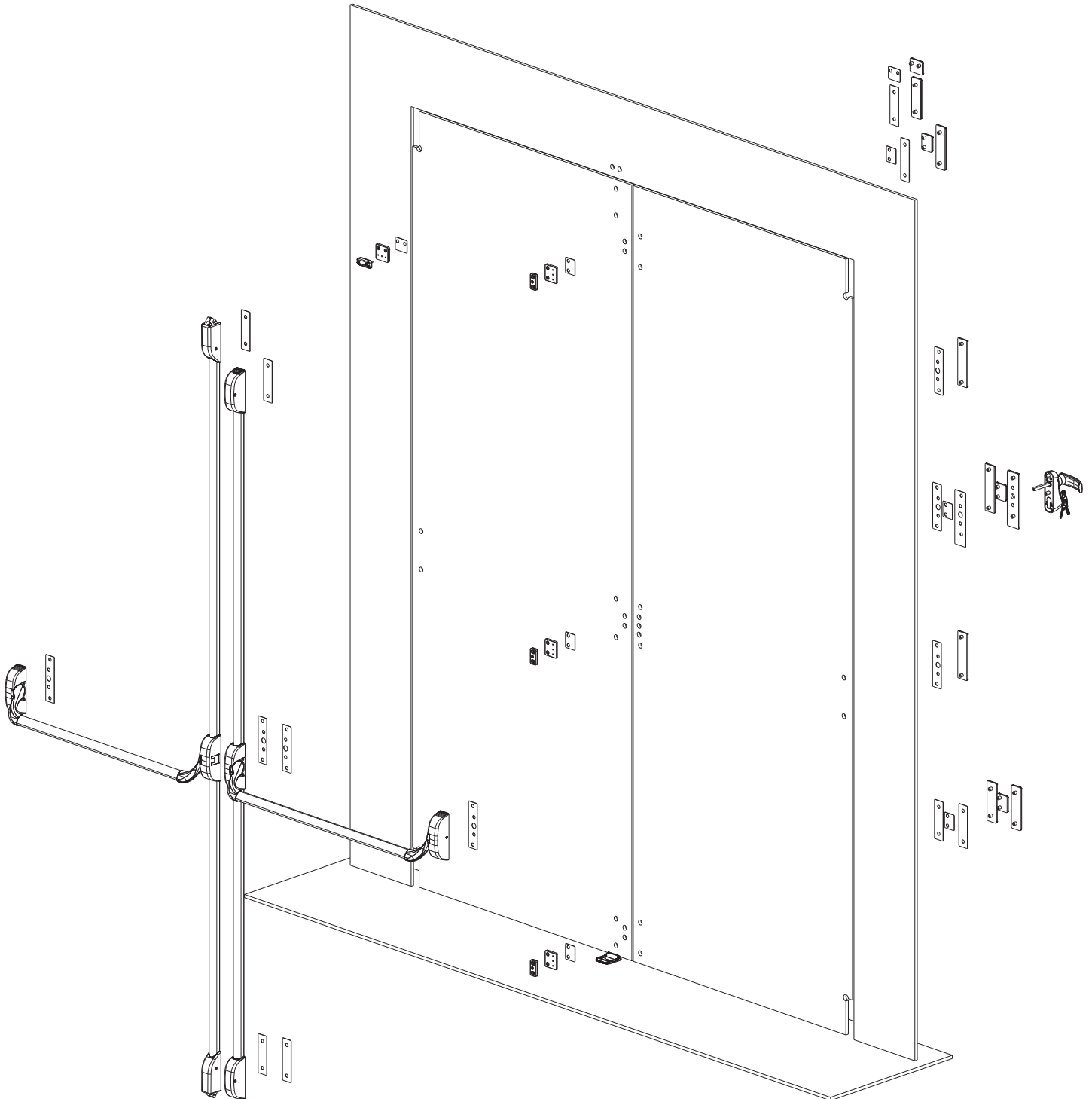
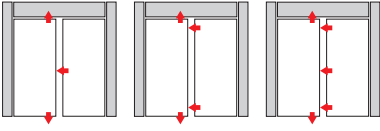

7a

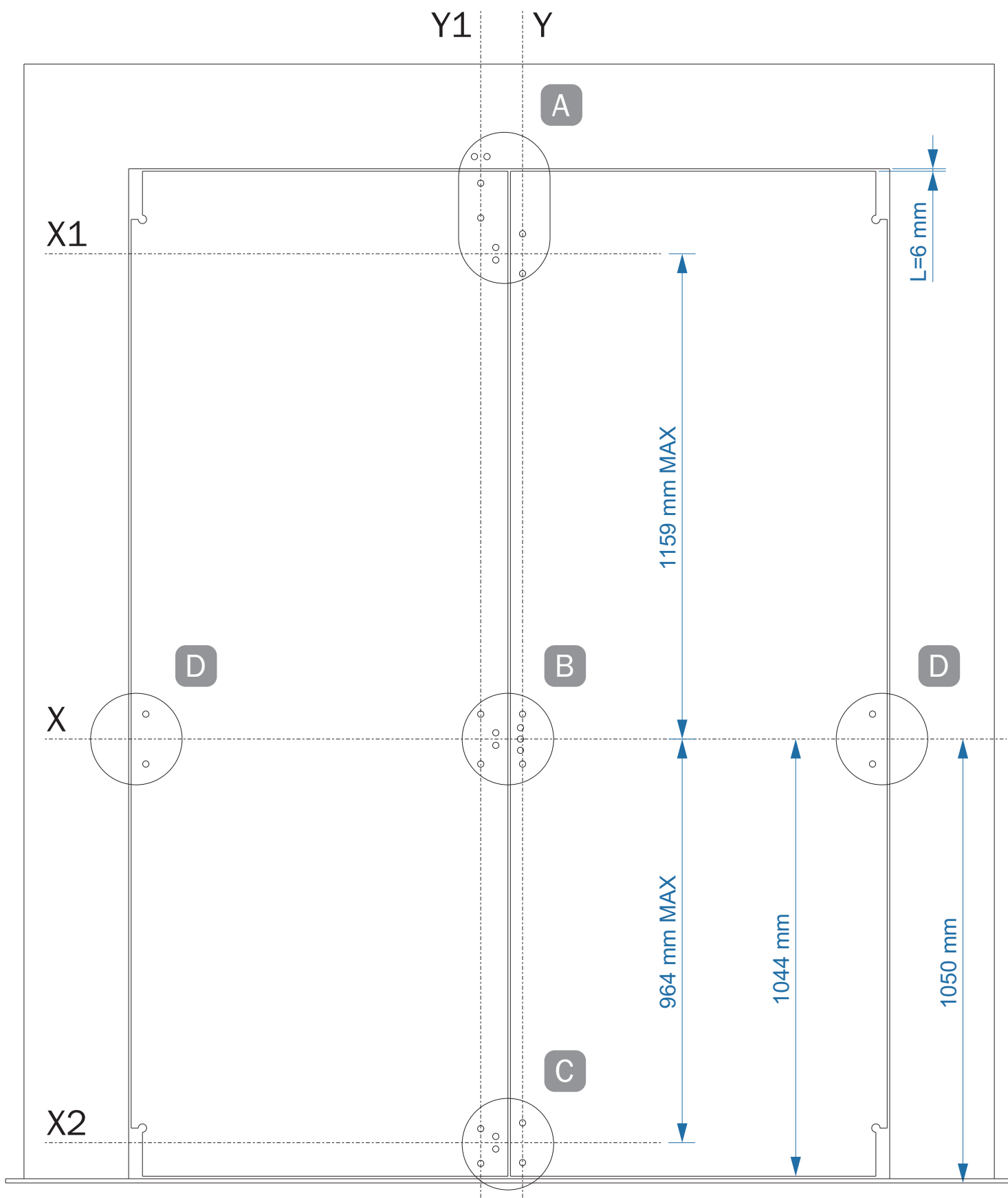

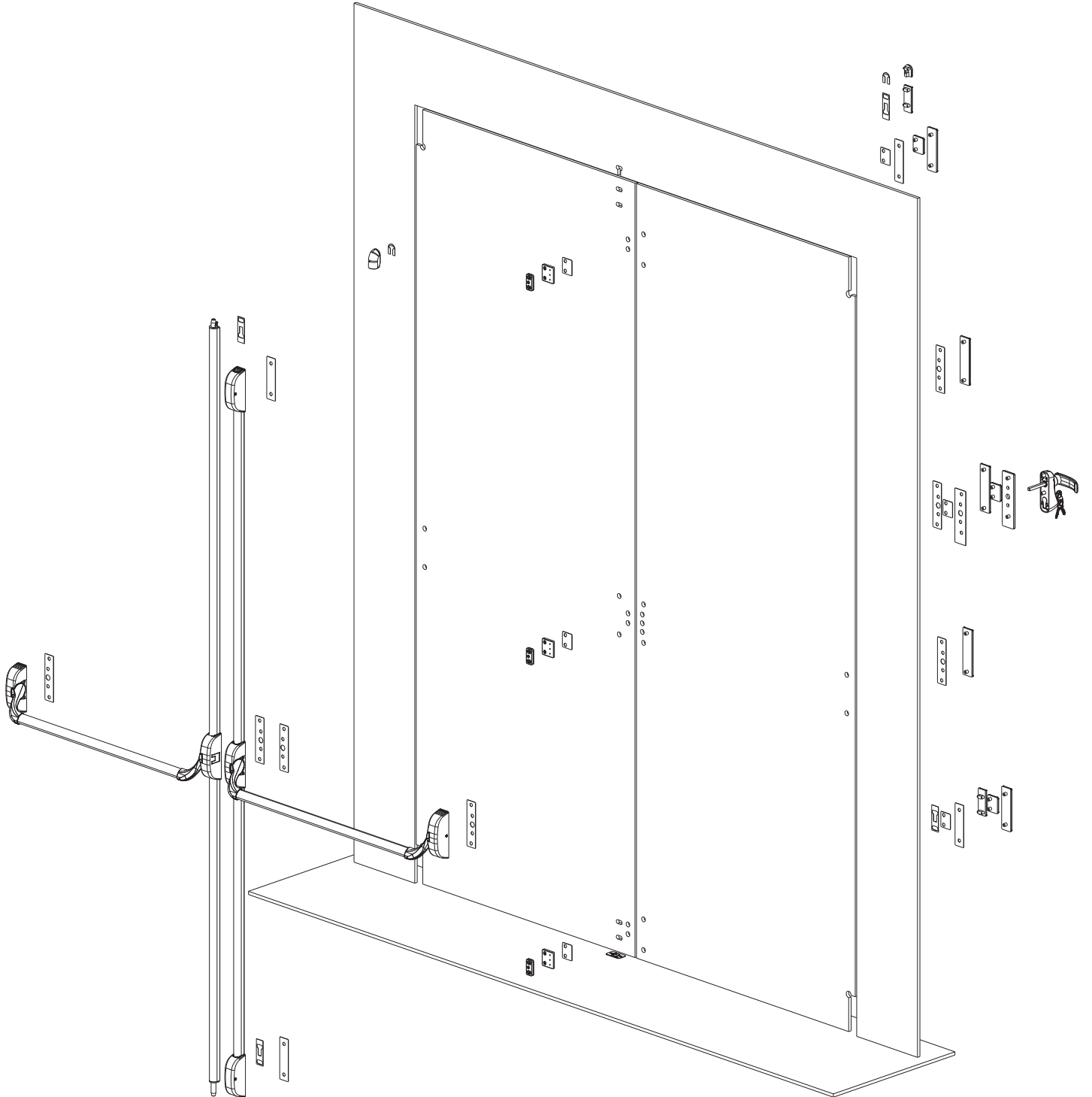
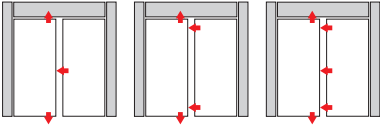

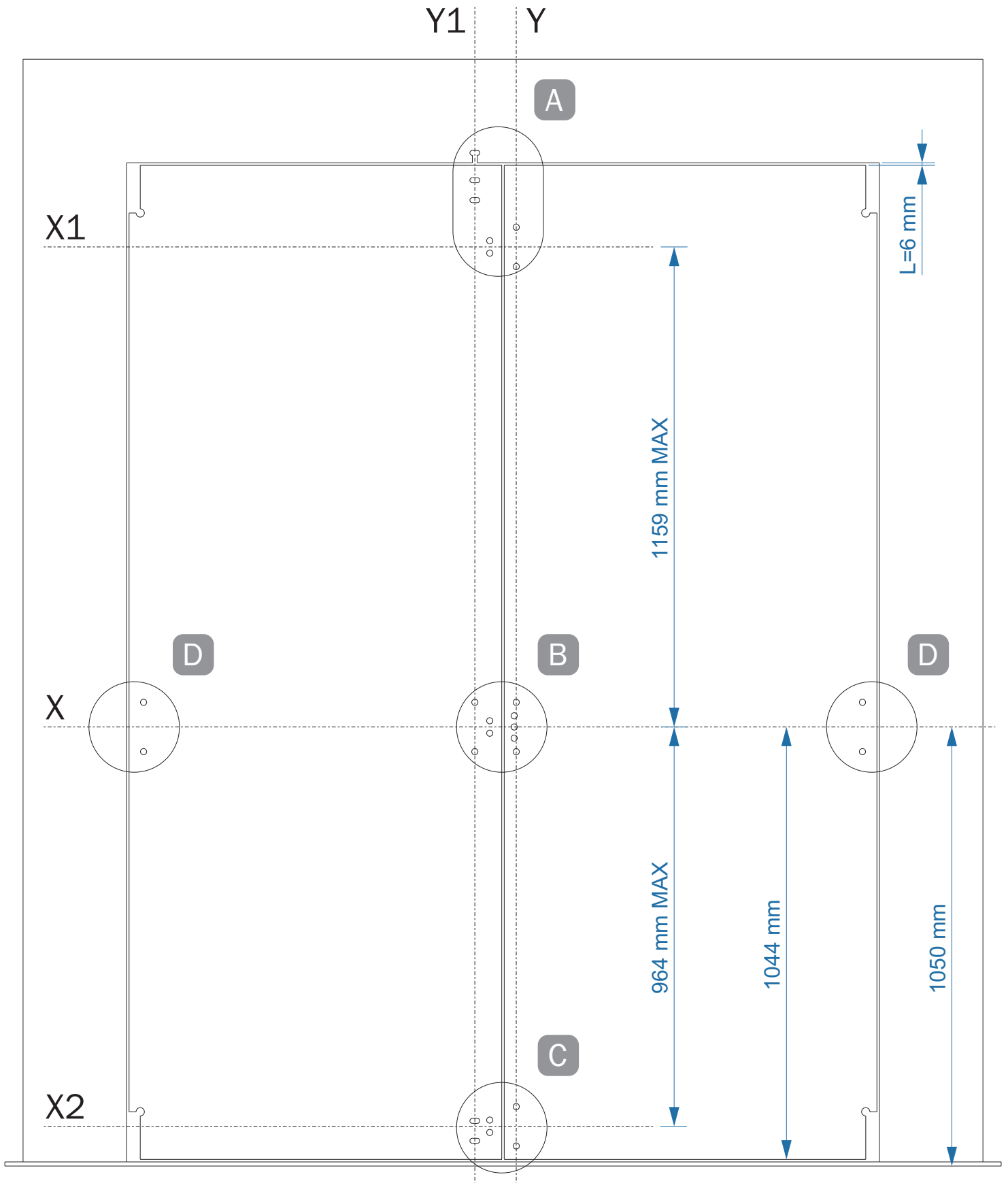

8b

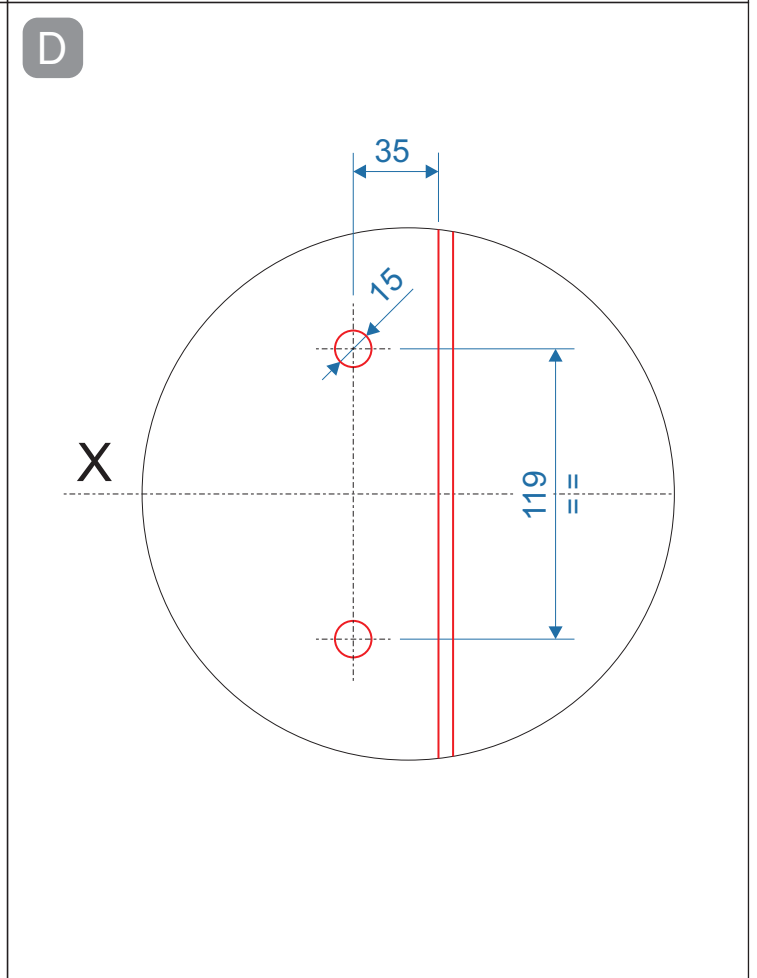
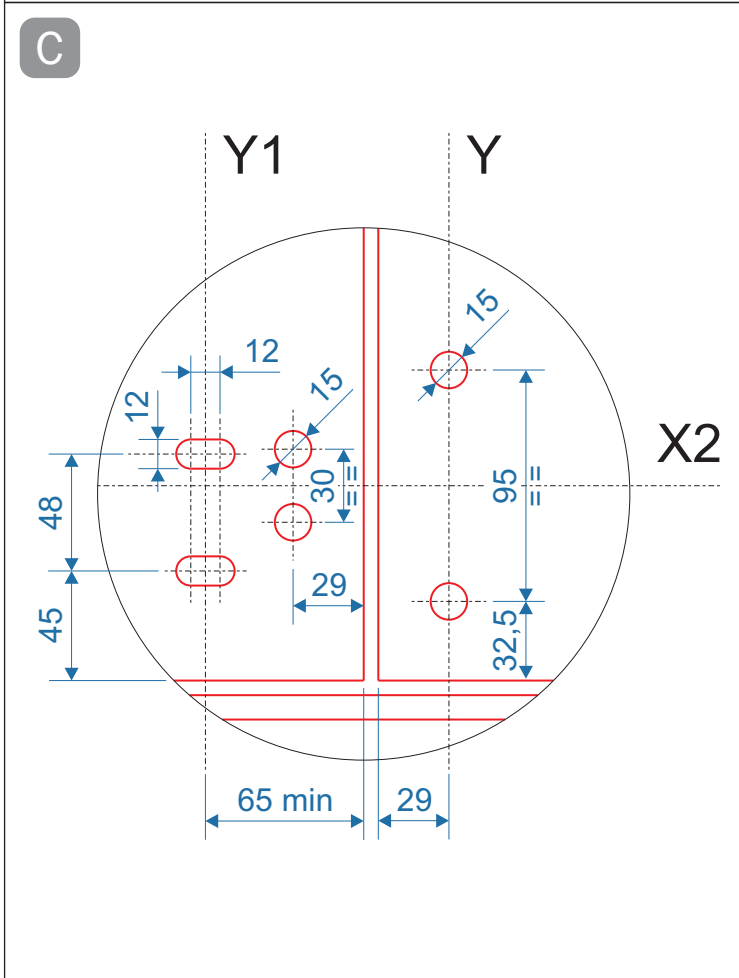
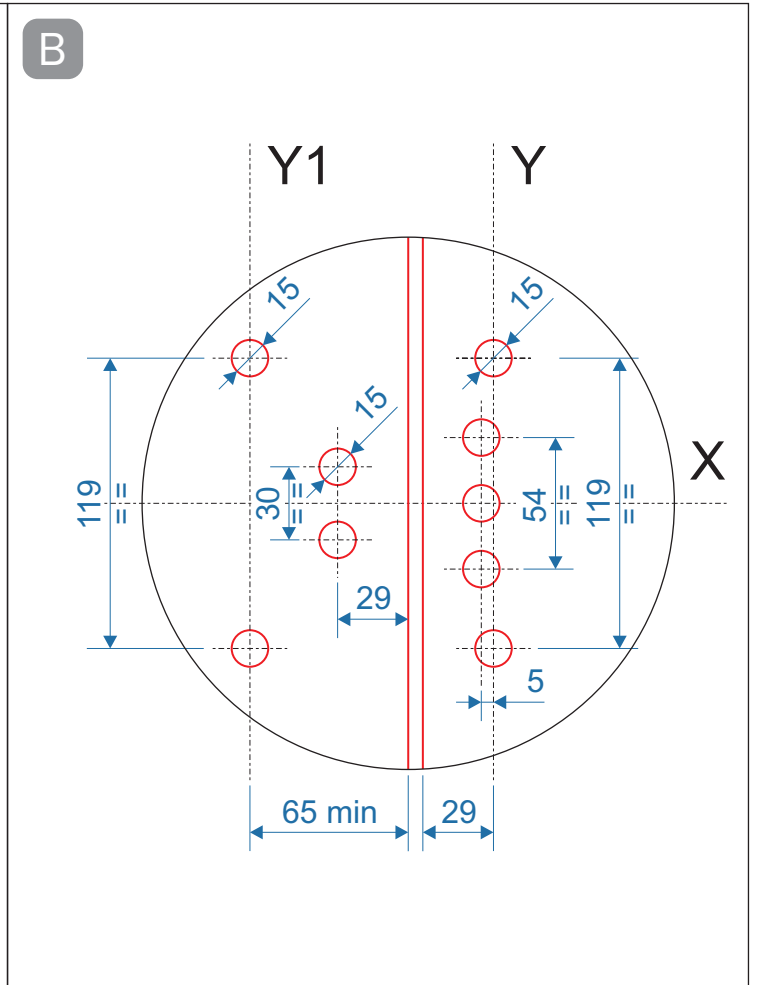
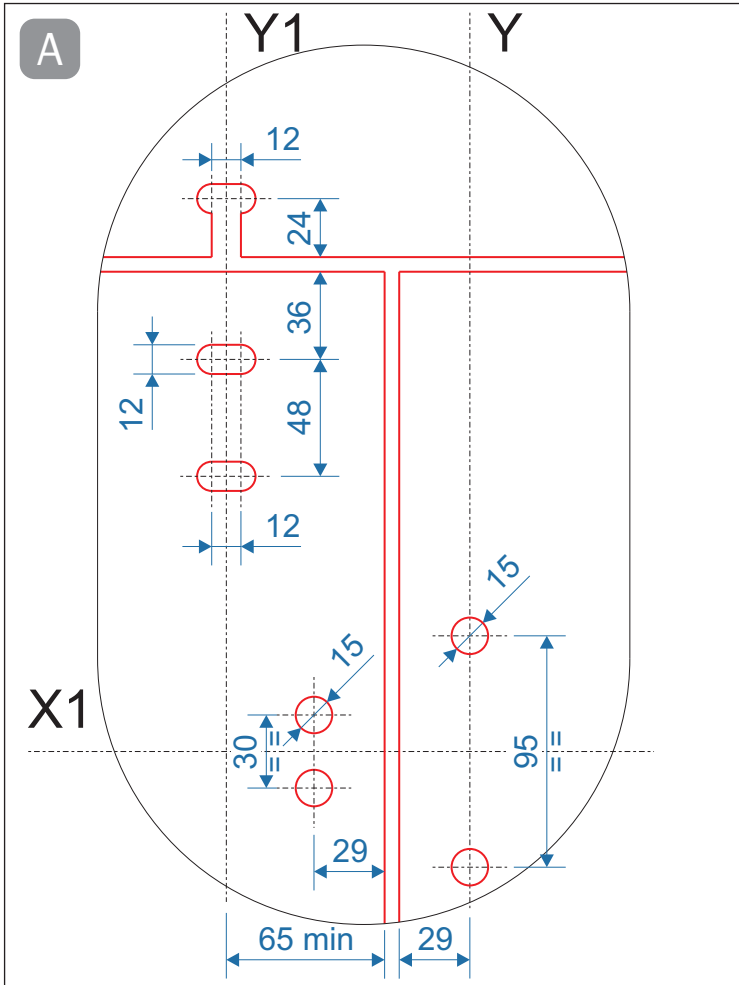

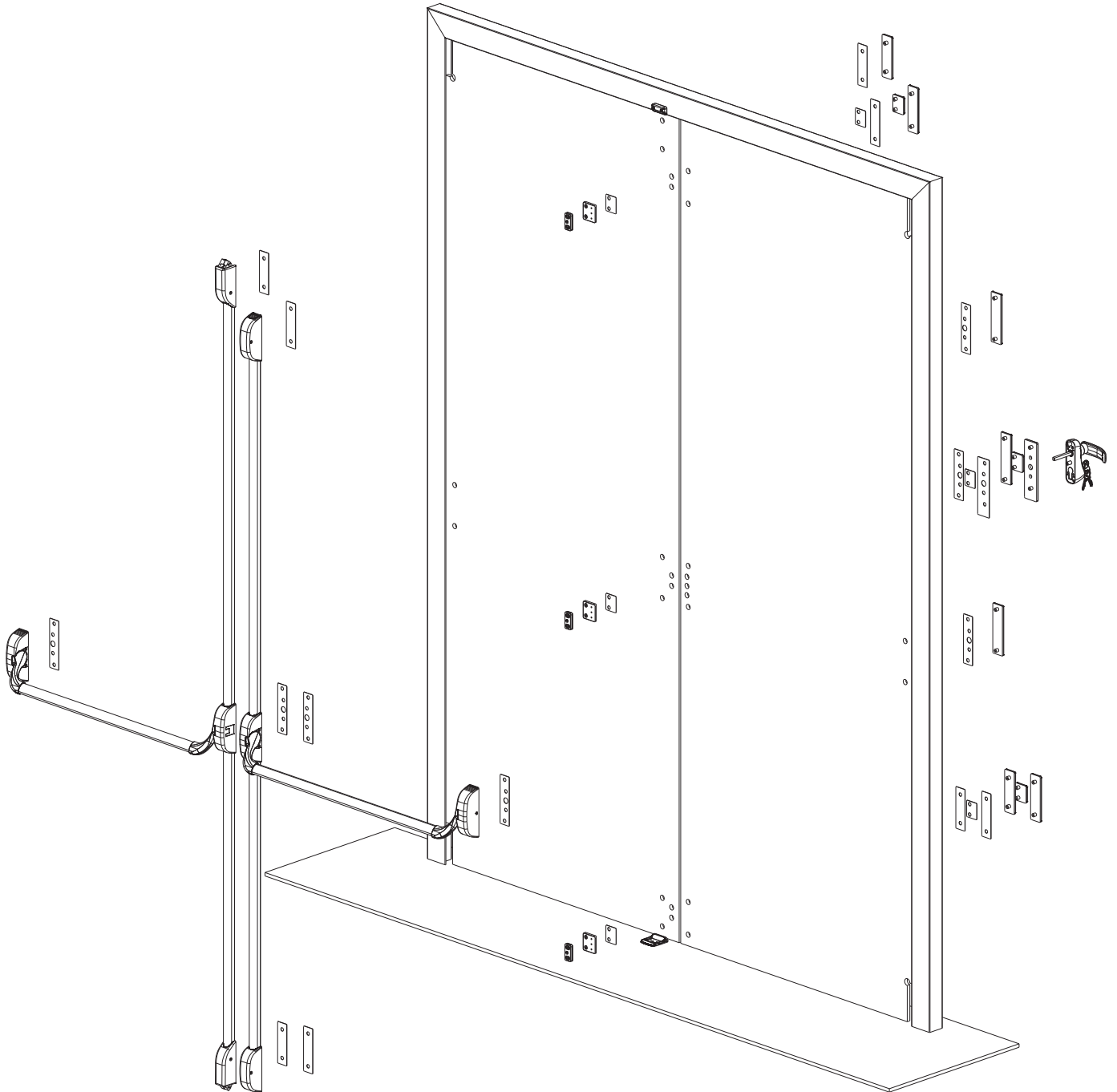
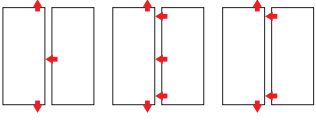

9a

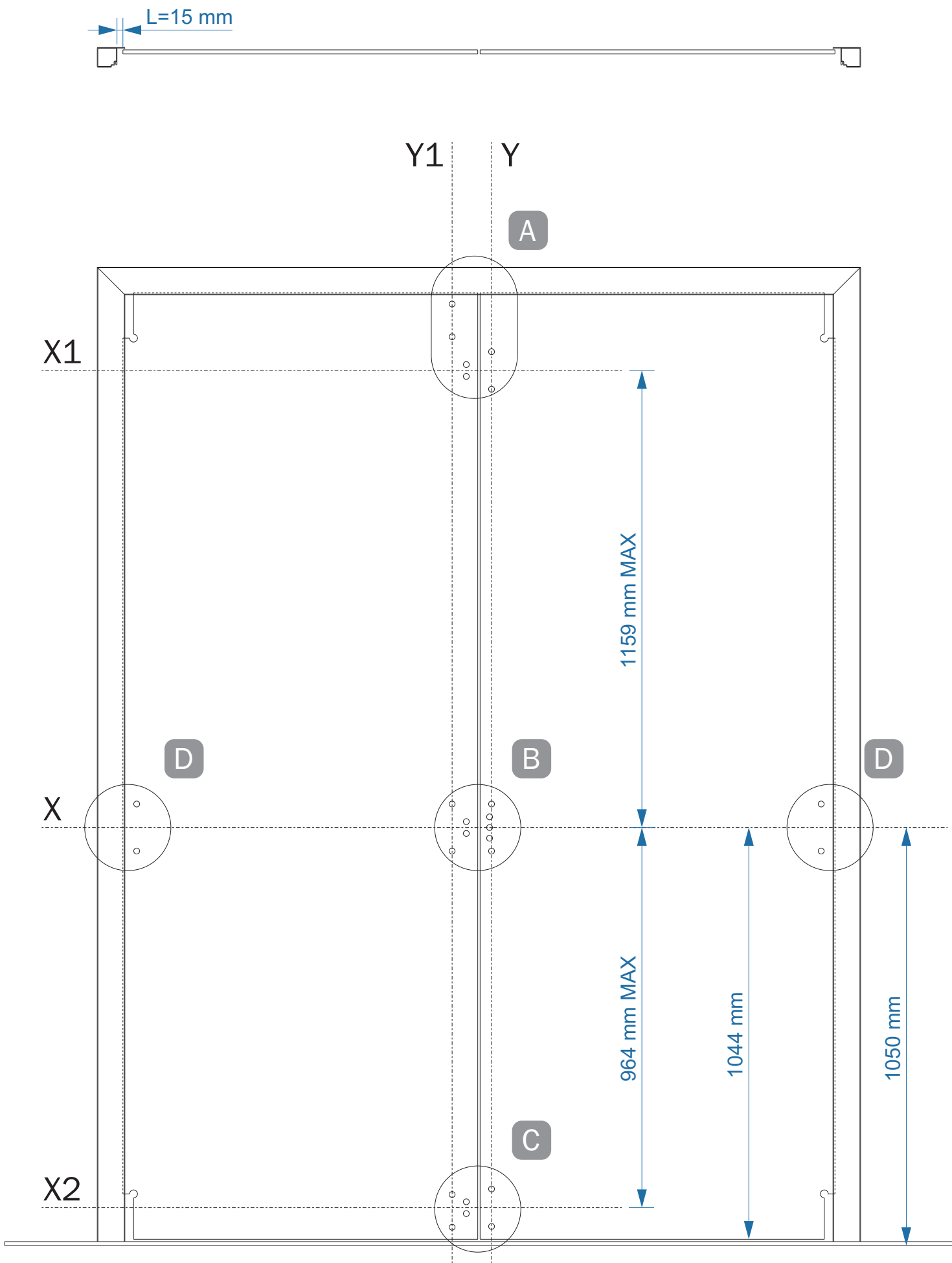

9b

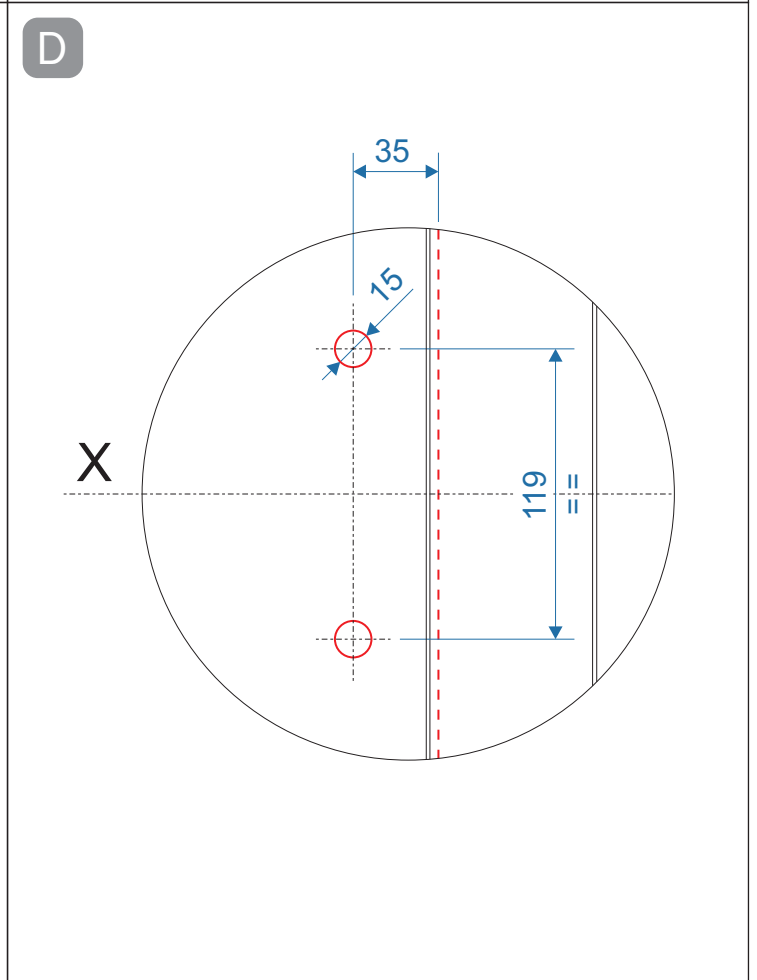
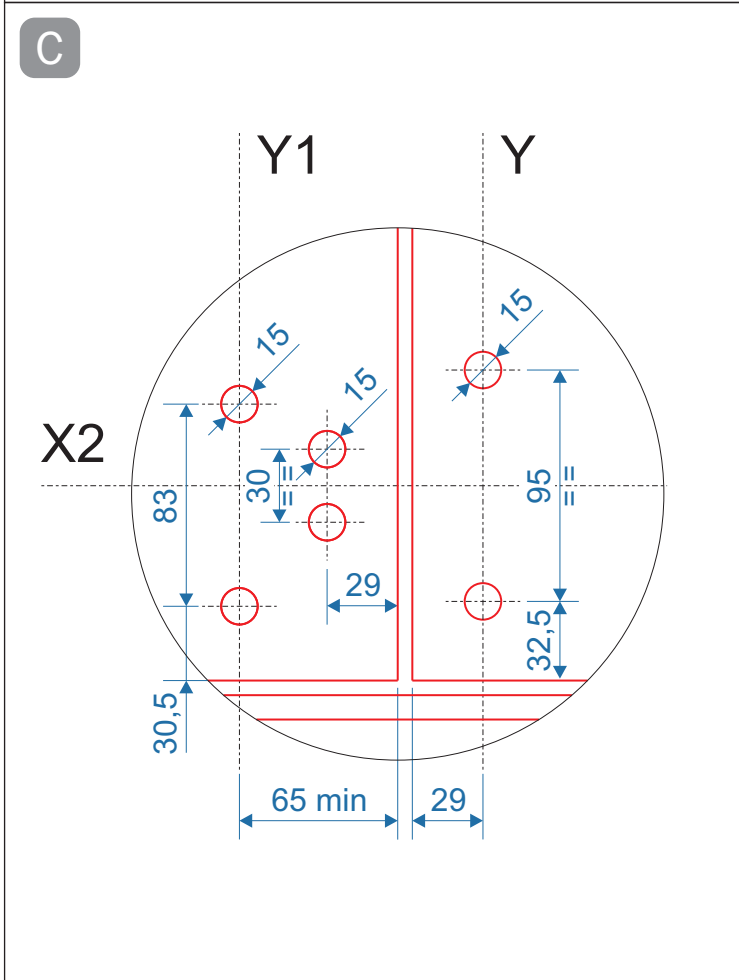
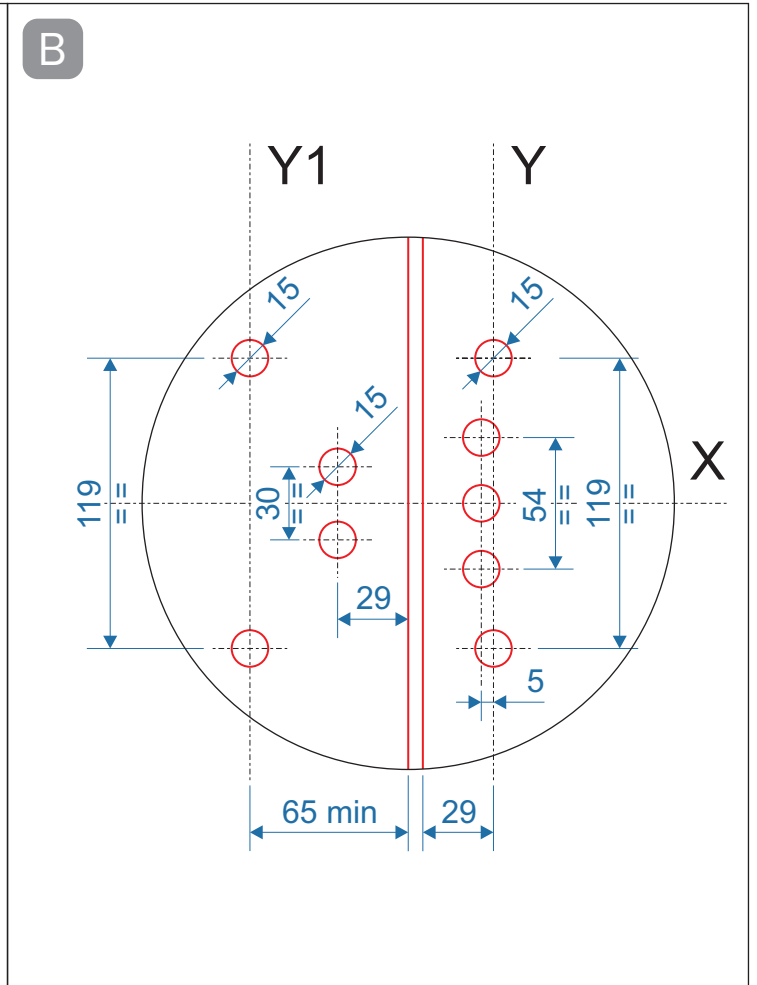
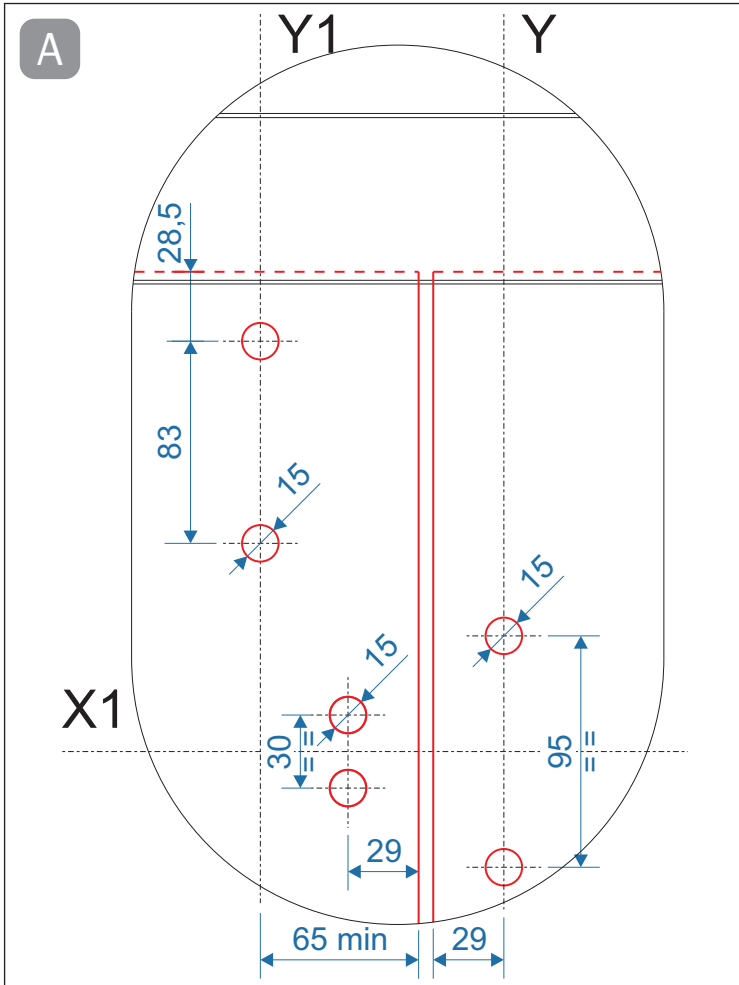

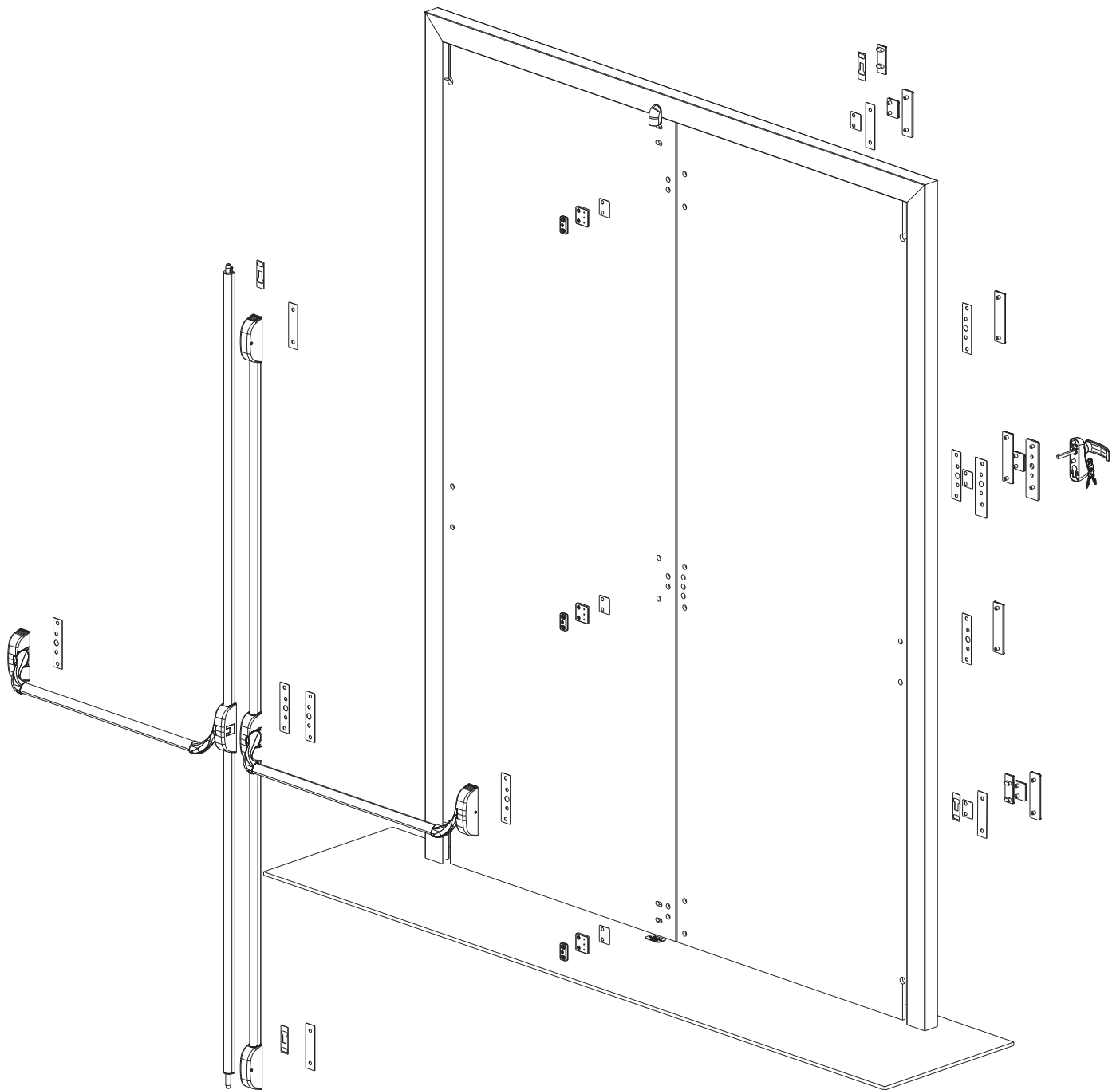
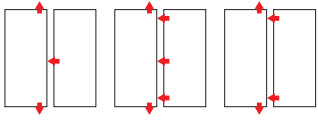

10a

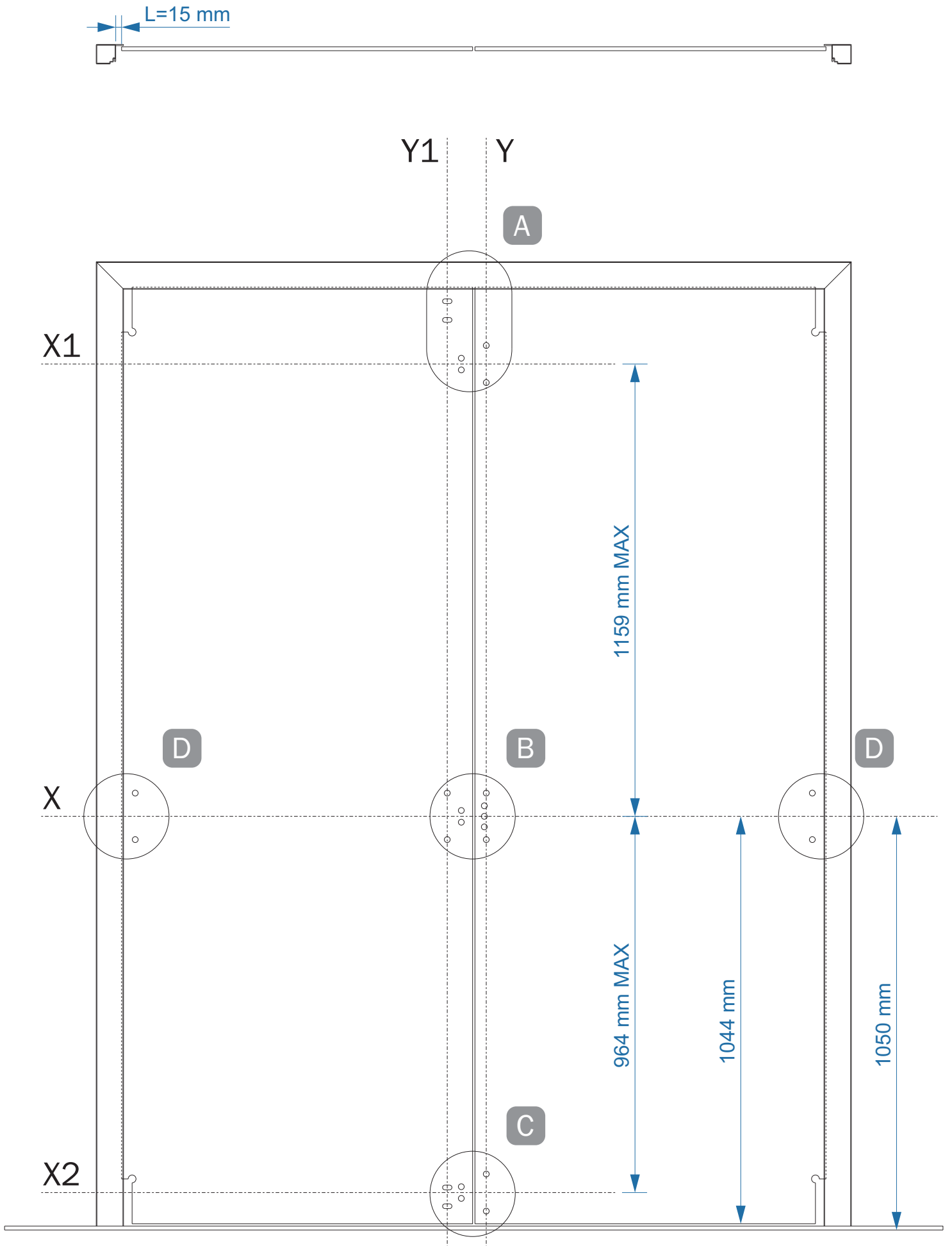

10b

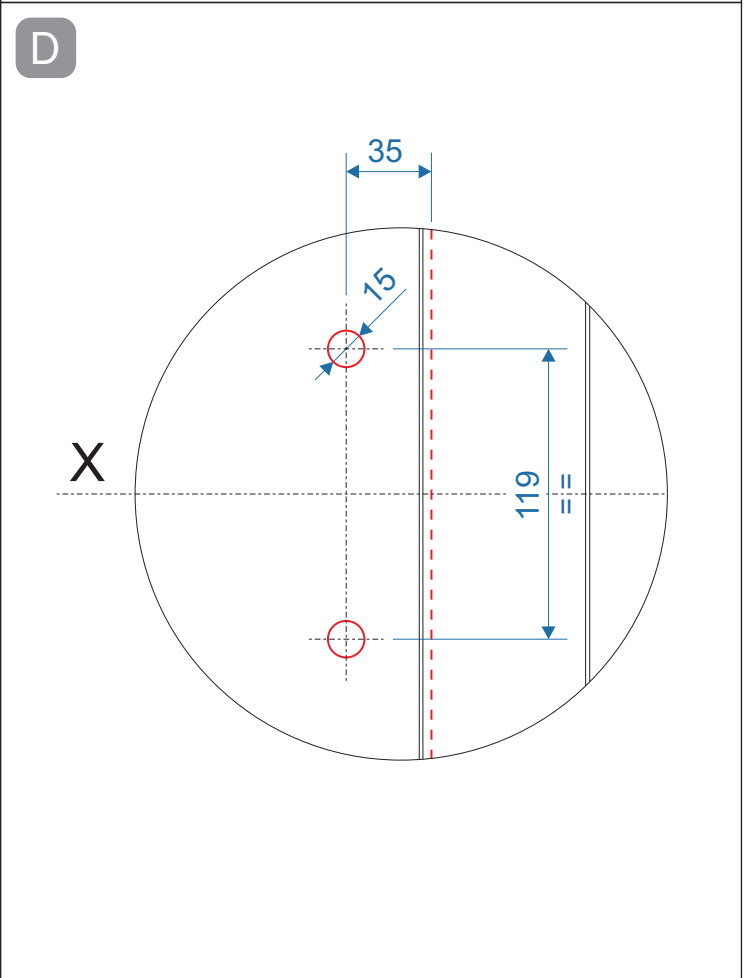
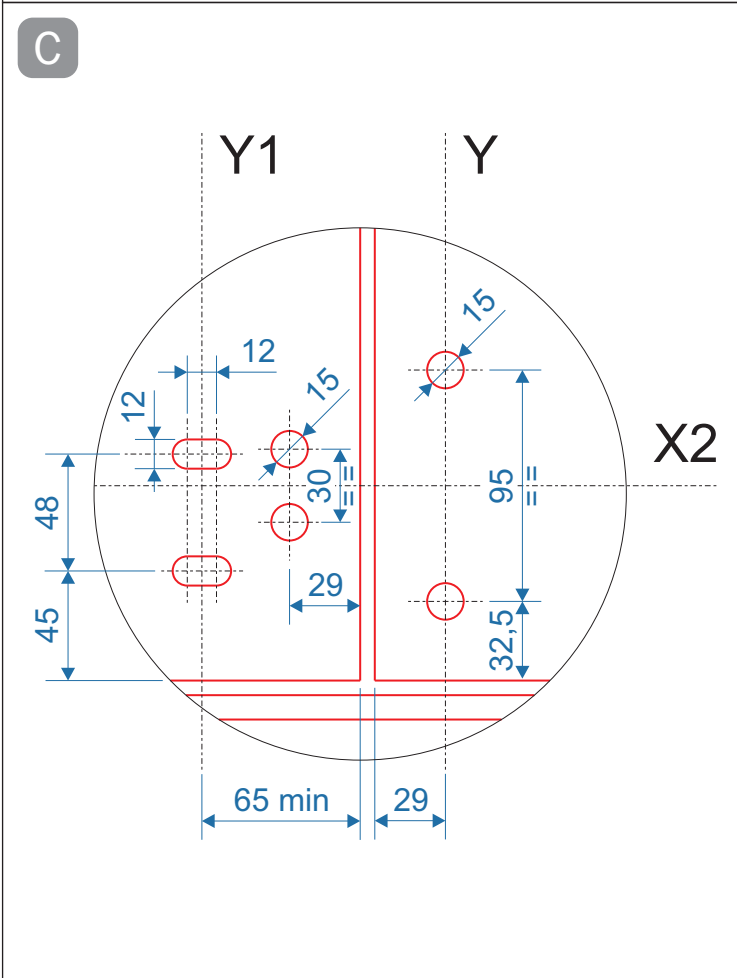
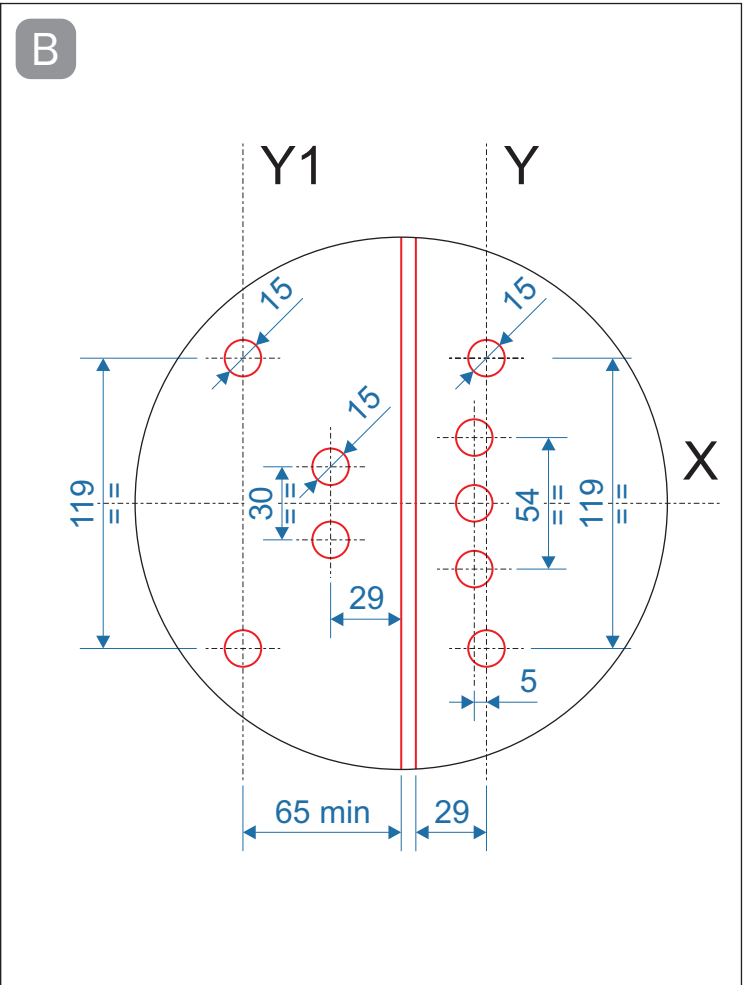
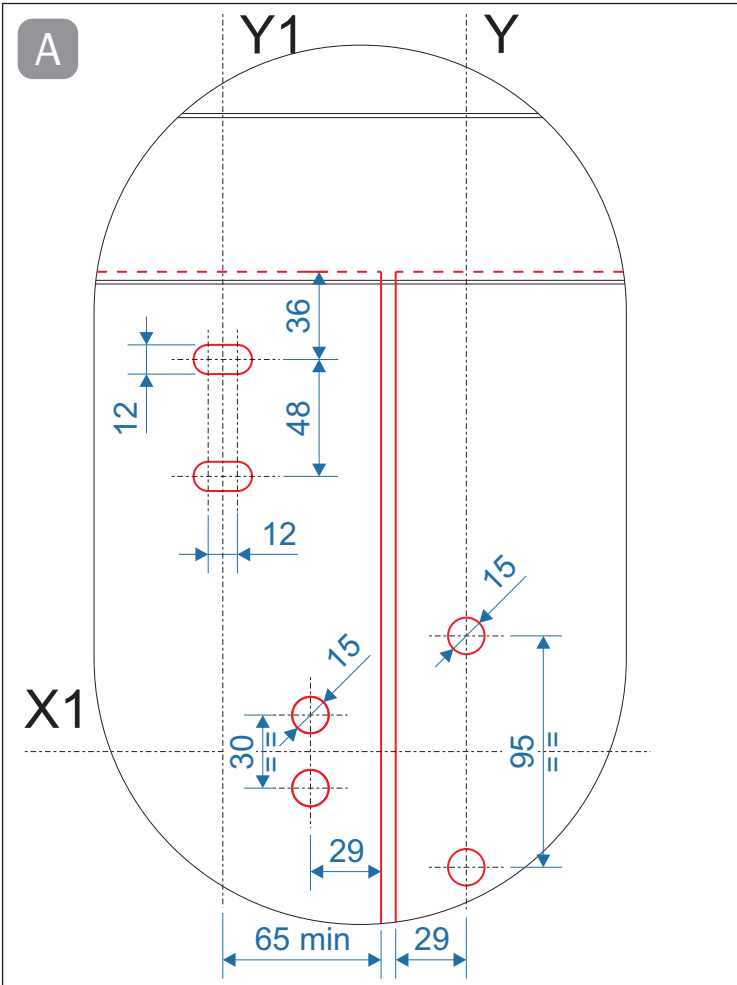

ATTENZIONE - ATTENTION - ATTENTION

Evitare il contatto vetro / metallo utilizzando materiale non metallico (PVC-Nylon-etc.)

Avoid contact between glass and metal by using non-metal material (PVC-Nylon, etc.)

Eviter le contact verre / métal si l'on utilise un matériau non métallique (PVC-Nylon-etc.)

Den Glas/Metall-Kontakt durch den Einsatz von nichtmetallischem Material (PVC-Nylon-usw.) verhindern

Evitar el contacto cristal/metal utilizando material no metálico (PVC-Nylon-etc.)

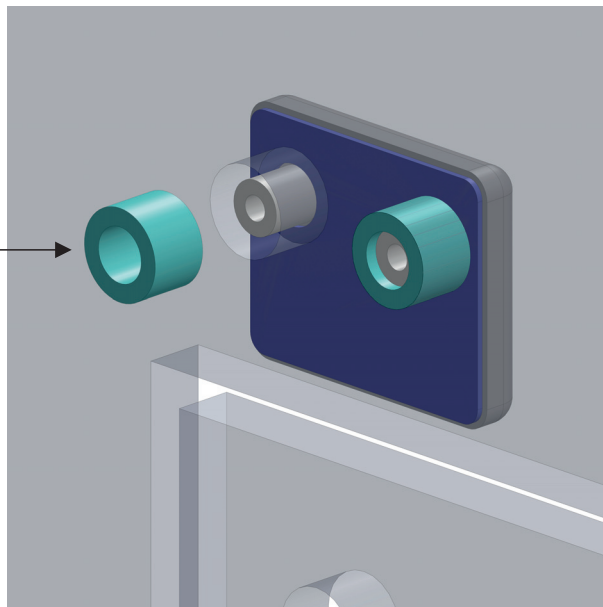

kit. 94100616

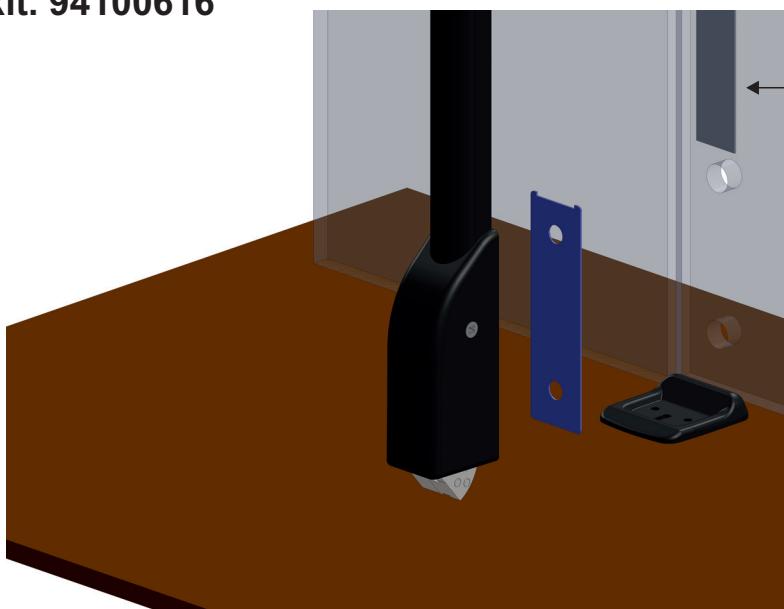

94100616

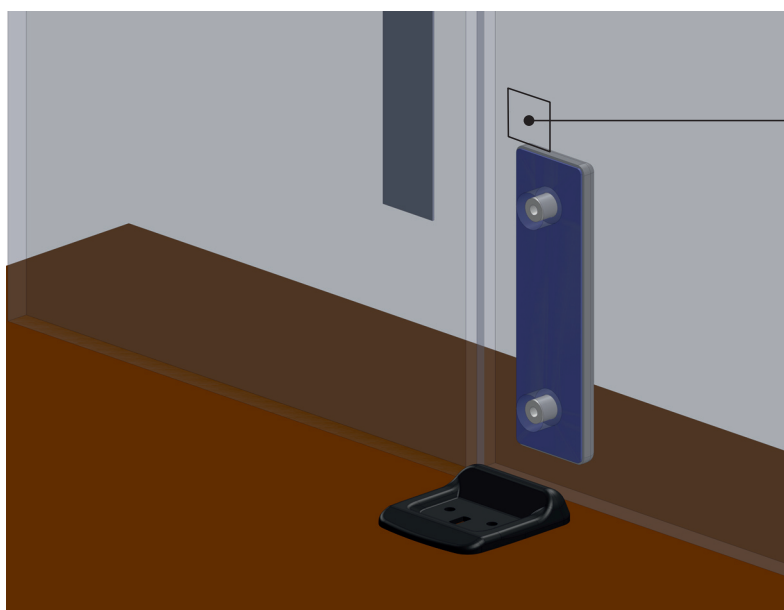
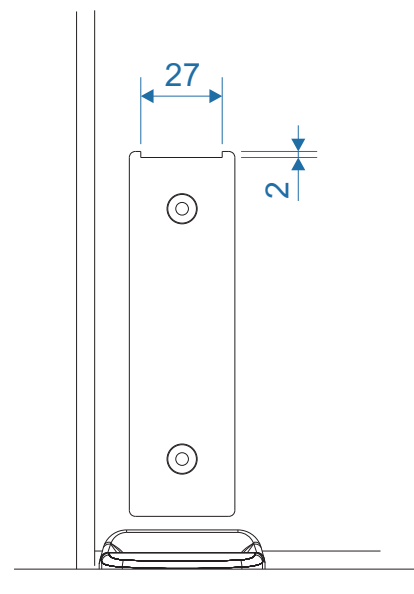











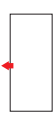
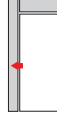

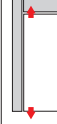

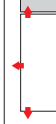
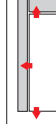

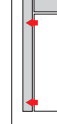
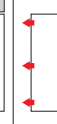
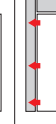
FISSAGGIO - FIXING - FIXATION

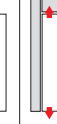
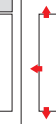
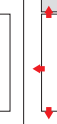
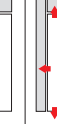
Utilizzare colla o nastro biadesivo
Use glue or double-sided tape

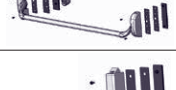









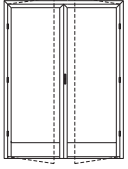

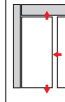
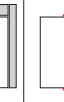

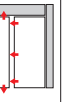
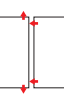
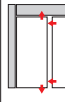
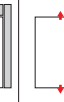
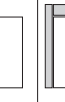
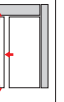
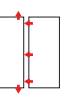
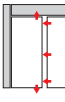
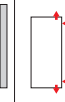
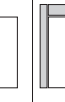
Utilisez de la colle ou du ruban adhésif double-face

Verwenden Klebstoff oder doppelseitigem Klebeband

Utilice pegamento o cinta adhesiva de doble cara

		Base										Bolt						
																		
94100506																		
94100516		▲	▲	▲	▲	▲	▲	▲	▲	▲	▲	▲	▲	▲	▲	▲	▲	▲
94100526																		
94100566				1pz	1pz	1pz	1pz	1pz										
94100576									1pz	1pz	1pz	1pz						
94100586													1pz	1pz	1pz	1pz	1pz	
94100596			1pz		1pz		1pz	2pz		2pz		3pz						1pz
94100606													1pz			1pz		1pz
94100616				1pz	1pz	1pz	1pz	1pz	1pz	1pz	1pz	1pz	1pz	1pz	1pz	1pz	1pz	1pz

▲ = Scegliere 1 kit in funzione del comando esterno e della "mano" della porta - Choose 1 kit in relation to the external control and the door opening direction - Choisir 1 kit en fonction de la commande extérieure et du sens d'ouverture de la porte - Auf der externen Steuereinrichtung und der Türöffnungsrichtung basierend 1 Kit wählen - Elegir kit 1 en función del mando externo y de la dirección de apertura de la puerta

		Base						Bolt										
																		
94100506																		
94100516		■	■	■	■	■	■	■	■	■	■	■	■	■	■	■	■	■
94100526																		
94100566		1pz	1pz	1pz	1pz	1pz	1pz											
94100576				1pz	1pz	1pz	1pz											
94100586										1pz	1pz	1pz	1pz	1pz	1pz	1pz	1pz	
94100596		1pz	2pz	3pz	4pz	2pz	3pz	1pz	2pz	3pz	4pz	2pz	3pz	4pz	2pz	3pz		
94100606										1pz		1pz						1pz
94100616		1pz	1pz	2pz	2pz	2pz	2pz	1pz	1pz	2pz	2pz	2pz	2pz	2pz	2pz	2pz	2pz	2pz

■ = Scegliere 2 kit in funzione del comando esterno e della "mano" della porta - Choose 2 kits in relation to the external control and the door opening direction - Choisir 2 kits en fonction de la commande extérieure et du sens d'ouverture de la porte - Auf der externen Steuereinrichtung und der Türöffnungsrichtung basierend 2 Kits wählen - Elegir kit 2 en función del mando externo y de la dirección de apertura de la puerta

