

Test Report
No. 11-000305-PR02
(PB04-Z06-G03-04-en-01)



This is a translation of the test report 11-000305-PR02 (PB04-Z06-G03-04-de-01)
dated 4 July 2011

Date 03 August 2011

Client C.C.E. srl
Costruzioni Chiusure Ermetiche
Via dell' Artigianato 16
35010 Villa del Conte (PD)
Italy

Order Determination of the sound reduction index R
according to
EN ISO 10140-1 : 2010,
EN ISO 10140-2 : 2010
Rating according to EN ISO 717-1 :
1996+A1:2006

Object Floor seal type"20/30 ASDB" in a high-
performance sound insulating doorset

Contents

- 1 Object
- 2 Procedure
- 3 Detailed results
- 4 Instructions for use

Data sheet (1 page)
Total 8 pages



1 Object

1.1 Description of test specimen

Building element	Floor seal in a high-performance sound insulating doorset
Product designation	20/30 ASDB
Floor seal	floor drop seal, hinge-side activation, screw-fastened into sealing groove, mechanism with 2 contact pressure points
Type*	20/30 ASDB
Dimensions of casing (Width / Height / Length)	20 mm × 30 mm x 959 mm
Material of casing*	Aluminium
Material of gasket of floor seal *	TPE
Length of gasket	Corresponds to frame rebate dimensions at floor (the frame rebate dimensions - nominal opening width are: 966 mm)
Groove width	20.2 mm
Groove depth	30.0 mm
Air gap / travel of seal	5.5 mm - 6.0 mm
Residual closing travel at start of activation	on lock side: 185 mm
Installation	floor seal screw fastened flush with groove platform
Floor	The floor seal operates against a flat steel bar
Joint depth	57 mm
Doorset	Base leaf 47 mm multilayer door leaf with single rebate, overlap and frame seal. Reinforcements made from lead, sheet steel and heavy-duty bituminous material. Steel sheet lining on both sides, coated with heavy-duty bituminous material, resp. chip board, cavities filled with absorption material. Linings taper towards the floor joint
Size of door leaf	985 mm × 1985 mm
Thickness of doorset	At top 200 mm, at bottom 57 mm
Seals	TPE cavity lip seal in frame and door leaf. Plastic sealant is applied to either side of seals at top and on sides. This side sealing starts at a height of 10 mm above floor.
Frame	Timber wrap-around frame
Design	25 mm Multiplex reinforced with lead and sheet steel, connecting joint of frame fully filled with foam and sealed on either side with plastic sealant.

The description is based on inspection of the test specimen at the **ift** Laboratory for Building Acoustics. Item designations/ numbers as well as material specifications were given by the client. (Further manufacturer data marked with *.)

1.2 Mounting in test rig

- The frame was mounted by the ift Laboratory for Building Acoustics flush with the source room side of partition's test opening of the door test rig „Z“, with suppressed flanking transmission according to EN ISO 10140-5:2010; the test rig features an insert frame with 5 cm continuous separating joint which is sealed in the test opening with permanently flexible closed-pore sealant.
- The high-performance sound insulation unit is described in Clause 1 "Object". The acoustic separation of the test rig was not bridged.
- The test opening was arranged with the bottom door edge being close to the floor.
- The door leaf was attached to the frame, both sides of the functional joint were additionally sealed on the sides (except side with 10 mm distance from bottom) and the top using elastic sealant, to prevent leakage through the functional joints at the top and the side.

1.3 Representation of test specimen

The structural details were examined solely on the basis of the characteristics to be classified. The illustrations are based on unchanged documentation provided by the client.

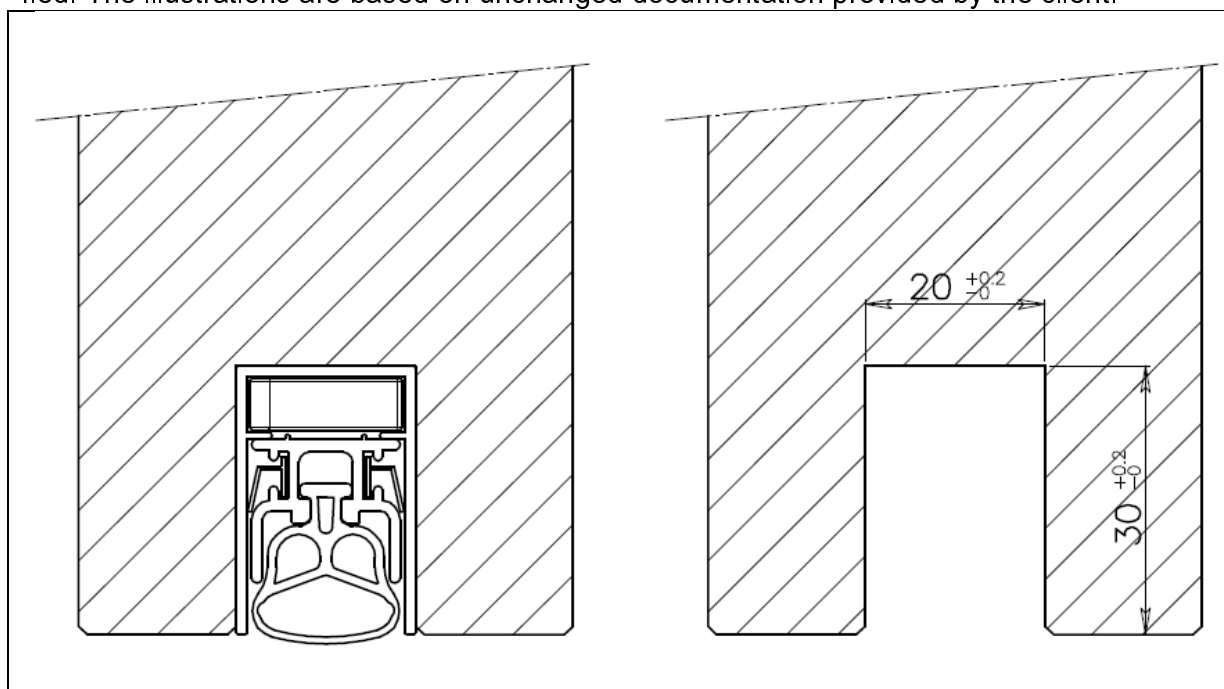

Figure 1 Sectional drawing 20/30 ASDB



2 Procedure

2.1 Sampling

Sampling	The samples were selected by the client.
Quantity	1
Manufacturer	CCE s.r.l.
Manufacturing plant	Villa del Conte (PD)
Date of manufacture /	April 2011
Date of sampling	
Responsible for sampling	Mr. Geron
Delivery to ift	5. May 2011 by the client
ift registration number	30233/003

2.2 Procedure

Goal of the investigation Test of the acoustic suitability of a lowerable floor seal type " 20/30 ASDB" for doors

Basis

EN ISO 10140-1:2010	Acoustics; Laboratory measurement of sound insulation of building elements - Part 1: Application rules for specific products (ISO 10140-1:2010)
EN ISO 10140-2:2010	Acoustics; Laboratory measurement of sound insulation of building elements - Part 2: Measurement of airborne sound insulation (ISO 10140-2:2010)
EN ISO 717-1: 1996 + A1:2006	Acoustics; Rating of sound insulation in buildings and of building elements - Part 1: Airborne sound insulation

Correspond/s to the national German standard/s:

DIN EN ISO 10140-1:2010-12, DIN EN ISO 10140-2:2010-12 and DIN EN ISO 717-1 : 2006-11

Boundary conditions As specified by the standard requirements with the exception of the below stated deviations.

Deviations The test setup was installed to determine the sound transmission through the floor joint. There fore a high-performance acoustic door leaf was mounted into a special frame and the top and side functional joints were sealed.

Test noise Pink noise

Measuring filter One-third-octave band filter



Background noise	The background noise level was not measured in the receiving room. No correction of sound insulation with background noise level was done.
Maximum sound insulation	Maximum sound insulation of the test setup for the floor seal was determined on the basis of the high-performance sound insulation door leaf described in Section 1. The difference between sound insulation and maximum sound insulation of the test setup is partly below 15 dB. It was corrected by calculation according to DIN EN ISO 10140-2 Annex B. The diagram annexed plots the maximum sound insulation.
Measurement of reverberation time	arithmetical mean: two measurements each of 2 loudspeaker and 3 microphone positions (total of 12 independent measurements).
Measurement equation A	$A = 0,16 \cdot \frac{V}{T}$ in m ²
Measurement of sound level difference	Minimum of 2 loudspeaker positions and rotating microphones
Measurement equation R	$R = L_1 - L_2 + 10 \cdot \lg \frac{S}{A}$ in dB

LEGEND / KEY

A	equivalent absorption area in m ²
L ₁	Sound pressure level source room in dB
L ₂	Sound pressure level receiving room in dB
R	Sound reduction index in dB
T	Reverberation time in s
V	Volume of receiving room in m ³
S	Testing area of the specimen in m ²

2.3 Test equipment

Device	Type	Manufacturer
Integrating sound meter	Type Nortronic 830	Norsonic-Tippkemper
Microphone preamplifiers	Type 1201	Norsonic-Tippkemper
Microphone units	Type 1220	Norsonic-Tippkemper
Calibrator	Type 1251	Norsonic-Tippkemper
Dodecahedron loudspeakers	Own design	-
Amplifier	Type E120	FG Elektronik
Rotating microphone boom	Own design / Type 231-N-360	Norsonic-Tippkemper

The **ift** Laboratory for Building Acoustics participates in comparative measurements at the Physikalisch-Technische Bundesanstalt (PTB) in Braunschweig every three years, the last one was in April 2010. The sound level meter used, Series No. 17956, was calibrated by the Dortmund Eichamt (calibration agency) on 16 September 2009. The calibration is valid until 31 December 2011.

2.4 Testing

Date	05 May 2011
Test engineer	Markus Schramm

3 Detailed results

The values of the measured sound reduction index of the high-performance sound insulating doorset with the tested floor seal are plotted as a function of frequency in the annexed data sheet and tabled.

As per EN ISO 717-1 the weighted sound reduction index R_w and the spectrum adaptation terms C and C_{tr} for the frequency range 100 Hz to 3,150 Hz obtained by calculation are as follows:

$$R_w (C;C_{tr}) = 52 (-1;-1) \text{ dB}$$

According to EN ISO 717-1 the following additional spectrum adaptation terms are obtained:

$$\begin{array}{llll}
 C_{50-3150} & = & - \text{ dB} & C_{100-5000} & = & -1 \text{ dB} & C_{50-5000} & = & - \text{ dB} \\
 C_{tr,50-3150} & = & - \text{ dB} & C_{tr,100-5000} & = & -1 \text{ dB} & C_{tr,50-5000} & = & - \text{ dB}
 \end{array}$$

4 Instructions for use

The **ift guidance** sheet "Conditions and notes for the use of **ift** test documents" applies.

4.1 Validity

The data and results given relate solely to the tested and described specimen. Testing for sound insulation does not allow any statement to be made on any further characteristics of the present construction regarding performance and quality.

4.2 Test report is not an evidence of suitability/verification of applicability

This test report is not an evidence of suitability/verification of applicability as per DIN 4109: 1989-11.
It does not contain a calculated value.

4.3 Test standards

The standard series EN ISO 10140:2010 supersedes those, until the respective date, applicable parts of the standard series EN ISO 140 which describe laboratory tests. According to the two standard series, the test methods are identical.

ift Rosenheim
03 August 2011



Dr. Joachim Hessinger, Dipl.-Phys.
Head of Testing Department
Building Physics



Markus Schramm, M.Eng., Dipl.-Ing. (FH)
Operating Testing Officer
Building Acoustics

Sound reduction index according to ISO 10140 - 2

Laboratory measurements of airborne sound insulation of building elements



Client: C.C.E. srl

Costruzioni Chiusure Ermetiche, 35010 Villa del Conte (PD) (Italy)

Product designation 20/30 ASDB

Design of test specimen

Floor seal in a high-performance sound insulating doorset
 Dimensions of casing (w x h x l)
 20 mm x 30 mm x 959 mm
 Activation hinge-side
 Air gap / travel of seal 5.5 mm - 6.0 mm
 Length of gasket Corresponds to frame rebate dimensions at floor
 Dimensions of groove 20.2 mm x 30.0 mm
 Mounting floor seal screw fastened flush into sealing groove

Test date 05 May 2011
 Test opening 1.010 m x 2.010 m = 2.03 m²
 Partition wall Concrete double wall, insert frame
 Test noise pink noise
 Volumes of test rooms V_s = 101 m³
 V_r = 67.5 m³
 Maximum sound reduction index
 R_{w,max} = 58 dB (related to test surface)
 Mounting conditions
 Floor seal mounted into an ideal sound insulating door leaf
 Climate in test rooms 18 °C / 46 % RF / 966 hPa

f in Hz	R in dB
50	-
63	-
80	-
100	48.1*
125	46.0*
160	46.6*
200	46.9*
250	47.4*
315	50.8*
400	52.7*
500	53.5*
630	53.3*
800	52.9*
1000	53.9*
1250	54.0*
1600	52.2
2000	50.7
2500	48.5
3150	49.3
4000	50.6
5000	52.4

*= Correction with maximum sound reduction
 Difference ≤ 6dB

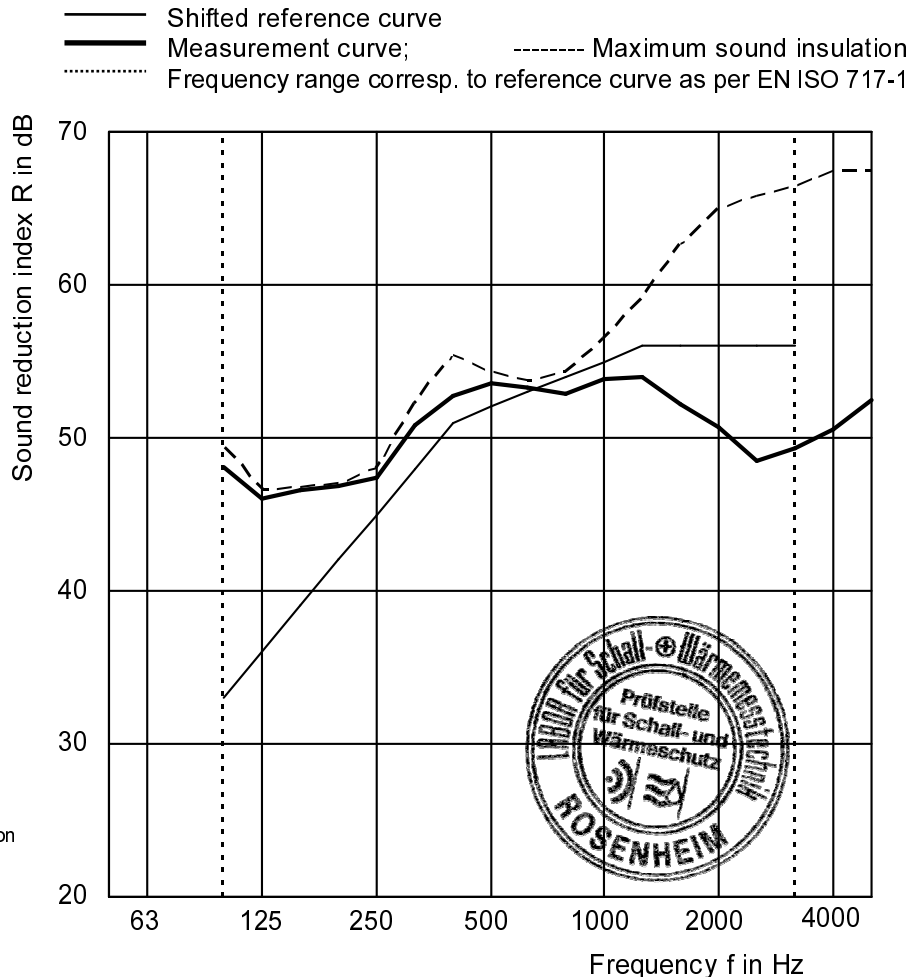

Rating according to EN ISO 717-1 (in third octave bands):

R_w (C;C_{tr}) = 52 (-1;-1) dB
 C₅₀₋₃₁₅₀ = - dB; C₁₀₀₋₅₀₀₀ = -1 dB; C₅₀₋₅₀₀₀ = - dB
 C_{tr,50-3150} = - dB; C_{tr,100-5000} = -1 dB; C_{tr,50-5000} = - dB

Test report No.: 11-000305-PR02 (PB04-Z06-G03-04-en-01)

Page 8 of 8

ift Rosenheim, Laboratory for Building Acoustics
 03 August 2011

Markus Schramm, M.Eng., Dipl.-Ing. (FH)
 Operating Testing Officer